

# OWNER'S MANUAL

## LCD Colour TV



24PS10E  
24PS10T  
24PS10V  
24PS10ZE  
32PS10E  
32PS10T  
32PS10V  
32PS10ZE  
40PS10E  
40PS10T  
40PS10V  
40PS10ZE

### Owner's Record

You will find the model number and serial number on the back of the TV. Record these numbers in the spaces provided below. Refer to them whenever you call upon your TOSHIBA dealer regarding this product.

Model number:

Serial number:

# Introduction / Getting started

## Contents

### Introduction / Getting started

Connecting an aerial .....	7
Exploring your new TV .....	7
TV front and side panel controls .....	7
TV back panel connections .....	8
Learning about the remote control .....	9
Turning the TV on .....	10
Tuning the TV for the first time .....	10
Using the Quick Menu .....	11
Learning about the menu system .....	11
Watching TV programmes .....	12
Programming channels into the TV's channel memory .....	12
Selecting the video input source to view .....	14
Channel List .....	14

### Using the TV's features

Picture adjustment .....	15
Sound adjustment .....	18
Other features settings .....	20
Teletext .....	21

### Connecting your TV

Back connections .....	23
Connecting HDMI or DVI devices .....	24
Selecting the PC/HDMI 1 Audio mode ...	25
Setting the HDMI 1 Audio mode .....	25
Connecting a computer .....	26
Using the PC Settings .....	27
Using the Media Player .....	27

### Reference section

APPENDIX .....	31
Troubleshooting .....	33
Broadcast system .....	34
Specifications .....	35

## Welcome to Toshiba

- Thank you for purchasing this Toshiba LCD Colour TV. This manual will help you use the exciting features of your new TV.
- Instructions in this manual are based on using the remote control.

- You also can use the controls on the TV if they have the same name as those referred to on the remote control.
- Please read all safety and operating instructions in this manual carefully, and keep this manual for future reference.

## Important Safety Instructions

Be sure to observe the following instructions and precautions to ensure safe use of this TV.

### Installation

- 1) WARNING: To prevent injury, this apparatus must be securely attached to the floor/wall in accordance with the installation instructions. Install the TV in a horizontal, stable location. Attach the TV to the stand with the mounting screw (not supplied on 24PS10 model).**
  - If the TV is not installed securely, it may lean or fall over and cause an injury.
  - To prevent injury, use the exclusive optional stand or wall-hanging bracket to install this TV on the floor or wall securely in accordance with a qualified technician.

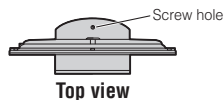

- 2) Never place the TV in an unstabilized location such as on a shaky table, incline or location subject to vibration.**
  - Only use cabinets or stands recommended by the TV manufacturer.
  - Only use furniture that can safely support the TV.
  - Ensure that the TV is not hanging over the edge of the supporting furniture.
  - Never place the TV on tall furniture (for example, cupboards or bookcases) without anchoring both the furniture and the TV to a suitable support.
  - Never stand the TV on cloth or other material placed between the TV and supporting furniture.

The TV may drop or fall off, which may cause an injury or damage.



**3) Never stand or climb on the TV.**

- Educate children about the dangers of climbing on furniture to reach the TV or its controls.

Be especially careful in households with children to prevent them through climbing on top of the TV. It may move, fall over, break, become damaged or cause an injury.



**4) Always connect the power plug to an appropriate electrical outlet equipped with 110-240V, AC 50/60Hz.**

Never use the TV outside the specified voltage range. It may cause a fire or an electric shock.

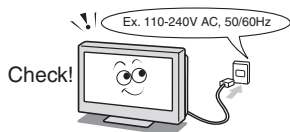

**About the fuse (only for E models)**

In a three pin earthing-type, the fuse fitted in this plug is approved by ASTA or BSI to BS1362. It should only be replaced by a correctly rated and approved type and the fuse cover must be refitted.

**5) Never insert or remove the power plug with wet hands.**

This may cause an electric shock.

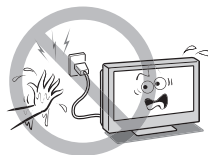

**6) Never block or cover the slots and openings in the cabinet.**

- Never place the TV so that it is facing upward or on its side.
  - Never place the TV in a closet, bookcase or other similar area where the ventilation is poor.
  - Never drape a newspaper, tablecloth or curtain on the TV.
  - When installing the TV against a wall, always keep the TV at least 10 cm away from the wall.
  - Never place the TV on a soft unstable surface, such as a carpet, or a cushion.
- The inside of this TV will overheat if the ventilation holes are covered, blocked or sealed, which may result in a fire.



**7) Never place the TV near a heater or in direct sunlight.**

The surface of the cabinet or power cord may melt and result in a fire or an electric shock.



- 8) Never place the TV in an area exposed to high humidity levels, such as in a bathroom or close to a humidifier.

This may cause a fire or an electric shock.



- 9) Never place the TV next to a stove where it will be exposed to oil, smoke, or steam, or in a location where there is a large quantity of dust.

This may cause a fire or an electric shock.



### 10) Precautions for moving the TV

- When moving the TV, be sure to remove the plug from the wall outlet and disconnect the aerial cable and audio/video cables, any steady ties and mounting screw. A fire or an electric shock may result if the power cord is damaged.
- When carrying the TV, at least two people are needed. Be sure to carry it upright.
- Never carry the TV with the screen facing up or down.



### 11) Precautions for installing on outdoor aerial

An outside aerial system should not be located in the vicinity of overhead power lines, or other electric light or power circuits.

If the aerial falls down or drops, it may cause an injury or an electric shock.



## Use

- 1) Never place hot objects or open flame sources, such as lighted candles or nightlights, on or close to the TV.

High temperatures can melt plastic and lead to fires.



- 2) The apparatus shall not be exposed to dripping or splashing and that no objects filled with liquids, such as vases, shall be placed on the apparatus.

When liquids are spilled inside the TV, this may cause a fire or an electric shock.

If small objects drop inside the TV, turn off the TV and remove the power plug from the outlet immediately and contact a service technician.



- 3) Never insert objects (metal or paper) or pour water inside the TV through ventilation holes and other openings.

These items may cause a fire or an electric shock. If these objects are inserted inside the TV, turn off the TV and remove the power plug from the outlet immediately and contact a service technician. Be especially careful that children do not insert objects in the TV.



- 4) When the TV will not be used for a long period of time, such as during vacation or travel, remove the power plug from the wall outlet for safety.

- The TV is not completely disconnected from the power supply line, as minute current is consumed even when the Power switch is turned off.

- The Mains plug or an appliance coupler is used as the disconnect device, therefore the disconnect device shall remain readily operable.



**5) Never pull on the power cord when removing the plug from the wall outlet.**

Always hold the plug firmly when removing it. If the power cord is yanked, the cord may become damaged and a fire or an electric shock may occur.



**6) Never cut, break, modify, twist, bunch up or bent the cord or apply excessive force or tension to it.**

Never place heavy objects on the cord or allow it to overheat as this may cause damage, a fire or an electric shock. Contact a service technician if the power cord is damaged.

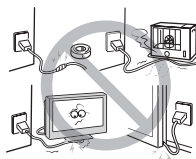

**7) If there is thunder or lightning, never touch the aerial cable or other connected cables.**

You may suffer an electric shock.



## Service

**1) Never repair, modify or disassemble the TV by yourself.**

It may cause a fire or an electric shock. Consult a service technician for inspection and repairs.



**2) When a malfunction occurs, or if smoke or an unusual odor comes from the TV, turn off the TV and remove the power plug from the outlet immediately.**

Make sure that the smoke or smell has stopped, then contact a service technician. If the TV is still used in this condition, it may cause a fire or an electric shock.



**3) If the TV is dropped or the cabinet is broken, turn off the TV and remove the power plug from the outlet immediately.**

If the TV has power in this condition, it may cause a fire or an electric shock. If the cabinet is broken, be careful when handling the TV to prevent an injury.

Contact a service technician for inspection and repair.

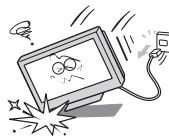

**4) When the TV reaches the end of its useful life, ask a qualified service technician to properly dispose of the TV.**



## Cleaning

### 1) Remove the power plug before cleaning.

Never use solvents such as benzene or thinner to clean the TV.

- These solvents may distort the cabinet or damage its finish.
- If rubber or vinyl products remain in contact with the TV for a long time, a stain may result.

If the cabinet becomes dirty, clean it with a soft, dry cloth.

When cleaning the surface of the LCD display, wipe the panel surface gently with a soft, dry cloth.



### 2) Periodically disconnect the power plug from the outlet and check it.

**If dust has collected on the power plug connectors, clean off the dust with a dry cloth.**

This dust may cause a fire due to reduced insulation on the plug.



## Important information

### 1) About LCD screen

- If you have the LCD screen facing to the sun, the LCD screen will be damaged. Be aware of locating the TV close to a window or outdoors.
- Never press the LCD screen strongly or scratch it, and never put anything on it. These actions will damage the LCD screen.

### 2) About cabinet and LCD screen

Never spray volatile compounds such as insecticide on the cabinet and LCD screen. This may cause a discolouration or damage the cabinet and LCD screen.

### 3) About afterimage

If a still picture is displayed, an afterimage may remain on the screen, however it will disappear. This is not a sign of malfunction.

### 4) Some pixels of the screen do not light up

The LCD display panel is manufactured using an extremely high level of precision technology, however sometimes some pixels of the screen may be missing picture elements or have luminous spots. This is not a sign of malfunction.

### 5) About Interference

The LCD display may cause interference in image, sound, etc. of other electronic equipment that receives electromagnetic waves (e.g. AM radios and video equipment).

### 6) About using under the low temperature places

If you use the TV in the room of 0°C or less, the picture brightness may vary until the LCD monitor warms up. This is not a sign of malfunction.

## Exemptions

- Toshiba is not liable for any damage caused by fires, natural disaster (such as thunder, earthquake, etc.), acts by third parties, accidents, owner's misuse, or uses in other improper conditions.
- Toshiba is not liable for incidental damages (such as profit loss or interruption in business, modification or erasure of record data, etc.) caused by use or inability to use of product.
- Toshiba is not liable for any damage caused by neglect of the instructions described in the owner's manual.
- Toshiba is not liable for any damage caused by misuse or malfunction through simultaneous use of this product and the connected equipment.

## Connecting an aerial

Optimum reception of colour requires a good signal and will generally mean that an outdoor aerial must be used.

The exact type and positioning of the aerial will depend upon your particular area.

Your Toshiba dealer or service personnel can best advise you on which aerial to use in your area.

Before connecting the aerial cable, turn off all main power switches.

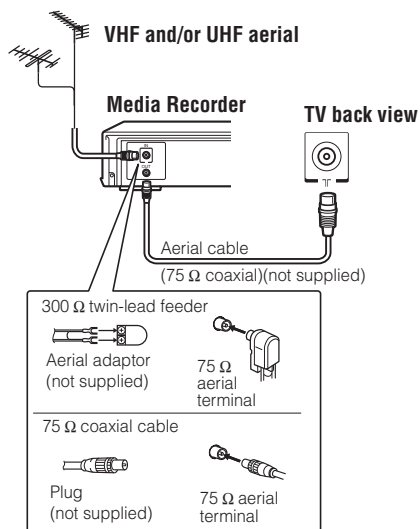

## Exploring your new TV

### Installing the remote control batteries

Remove the battery cover.

Insert two R03 (AAA) batteries matching the  $-/+$  polarities of the battery to the  $-/+$  marks inside the battery compartment.

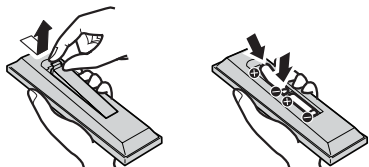

### Cautions:

- Dispose of batteries in a designated disposal area. Batteries must not be exposed to excessive heat such as sunshine, fire or the like.

- Attention should be drawn to the environmental aspects of battery disposal.
- Never mix battery types or combine used batteries with new ones.

### Notes:

- If the remote control does not operate correctly, or if the operating range becomes reduced, replace both batteries with new ones.
- If the batteries are dead or if you will not use the remote control for a long time, remove the batteries to prevent battery acid from leaking into the battery compartment.

### Effective range

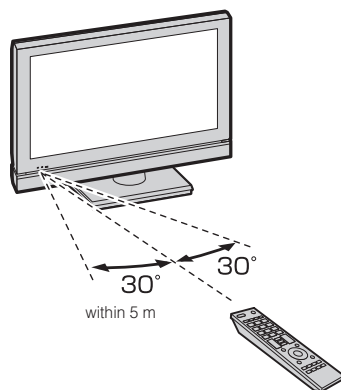

## TV front and side panel controls

- You can operate your TV using the buttons on the side panel or the remote control. The back of the panel provide the terminal connections to connect other equipment to your TV (see "Connecting your TV" pages 23 – 30).
- For the use of each control, see the pages in brackets.

### TV front view

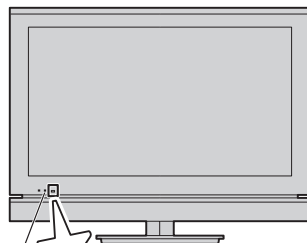

Point the brightness sensor (see page 18).

- (power LED) — Power indicator (see page 10).

## Left side view

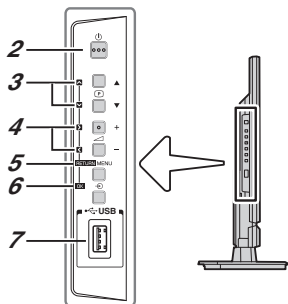

- 2 **⏻ (power on/standby)** — Press to turn the TV on/ standby (☞ page 10).
- 3 **⏪▲▼ (programme position)** — When no menu is on screen, these buttons select the programme position. (☞ page 12).  
**▲▼ (MENU up/down)** — When a menu is on-screen, these buttons function as up/down menu navigation buttons (except for the input source selection) (☞ page 11).
- 4 **◀ - + (volume)** — When no menu is on-screen, these buttons adjust the volume level.  
**<> (MENU left/right)** — When a menu is on-screen, these buttons function as left/right menu navigation buttons or adjust settings (☞ page 11).
- 5 **MENU** — Press to access the menu system (☞ page 11).  
**RETURN** — When a menu is on-screen, this button will take you back to the previous menu (☞ page 12).
- 6 **Ⓜ (input source selection)** — When no menu is on screen, this button selects the input source (☞ page 14).  
**OK** — When a menu is on-screen, this button will make a selection or take you to the next available menu layer (☞ page 11).
- 7 **USB (input terminal)** — Insert your USB storage device (photo, movie, music) (☞ page 28).

## TV back panel connections

Cable holder \*

- \* You can use the cable holder to hold the aerial cable, video and audio cables etc.

**Never grasp the holder when moving the TV.**

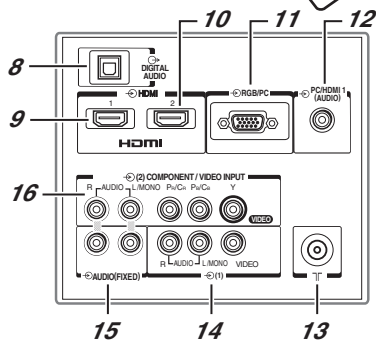
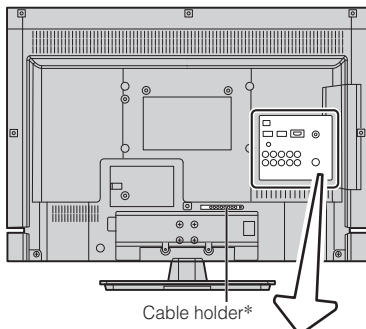

- 8 **Ⓜ DIGITAL AUDIO (OPTICAL) (output terminal)** — For use when connecting an amplifier with optical type digital audio input (☞ page 24).
- 9 **Ⓜ HDMI1 (input terminal)** — High-Definition Multimedia Interface input receives digital audio and uncompressed digital video from an HDMI device or uncompressed digital video from a DVI device (☞ pages 25, 26).
- 10 **Ⓜ HDMI2 (input terminal)** — High-Definition Multimedia Interface input receives digital audio and uncompressed digital video from an HDMI device (☞ page 25).
- 11 **Ⓜ RGB/PC (input terminal)** — For use when connecting a personal computer (PC) (☞ page 26).

- 12** **PC/HDMI 1 (AUDIO) (input terminal)** — PC audio input terminal is shared with HDMI analogue audio input terminal, and their use can be configured in the **SETUP** menu (see pages 25, 26).
- 13** **(aerial input terminal)** — Analogue aerial signal input (see page 7).
- 14** **(1) (Video 1 input terminals)** — Standard (composite) video and standard (analogue) stereo audio inputs (see page 23).
- 15** **AUDIO (output terminals)** — Standard audio outputs (FIXED) (see page 23).
- 16** **(2) COMPONENT / VIDEO INPUT (input terminals)** — High-definition component video and standard (analogue) stereo audio inputs, or standard (analogue) stereo audio inputs (see page 23).

- 19** **MENU** (see page 11)
- 20** When using the Media Player (▶▶▶◀◀◀ ■ ■▶▶▶◀◀◀ (see pages 29, 30)
- 21** Teletext control buttons (Four coloured buttons : Red, Green, Yellow, Blue) (see pages 21, 22)
- 22** To reveal concealed text (see page 22)
- 23** • To select a page while viewing a normal picture (see page 22)  
• To select the time display (see page 22)
- 24** To hold a wanted page (see page 22)
- 25** To enlarge the teletext display size (see page 22)

## Learning about the remote control

### Location of controls

- 1** Picture Size (see page 15)
- 2** Subtitle on/off (see page 21)
- 3** Input source selection (TV, VIDEO or COMPONENT, HDMI, PC) (see page 14)
- 4** Power on/Standby (see page 10)
- 5** Picture still (see page 16)
- 6** Stereo/Bilingual selection (see pages 18, 19)
- 7** Number buttons (0-9) (see pages 12, 20, 21)
- 8** To display the Channel List (see page 14)
- 9** To return to the previous programme (see page 12)
- 10** • To display on-screen information (see page 12)  
• Initial/Index function for Teletext (see page 22)
- 11** Sound Mute (This button turns the sound off/on.)
- 12** Programme position ^ v (see page 12)
- 13** Volume - + (These buttons adjust the volume level.)
- 14** **EXIT** (see page 12)
- 15** To access the Quick Menu (see page 11)
- 16** Teletext on/Superimpose Teletext/off (see page 21)
- 17** • Menu (see page 11)  
• **OK** (see page 11)
- 18** To return to the previous menu (see page 12)

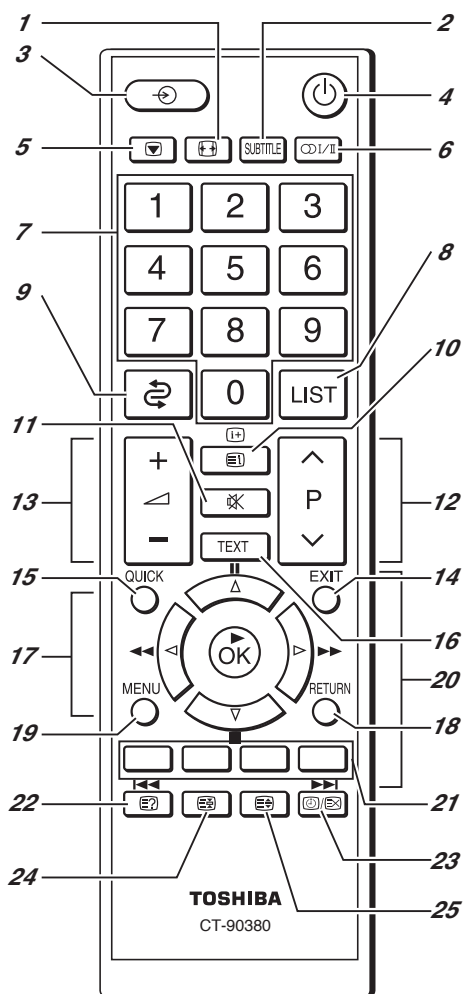

## Turning the TV on

### Switching on the TV

Connect the power cord to a wall outlet, the ⏻ power indicator lights in red (standby mode).

- 1 Press  on the remote control or on the TV left side panel, the ⏻ power indicator lights in green.

#### Note:

If you watch black and white programmes when the **Colour System** mode is set to Auto, colour noise may appear on the screen. In this case select the appropriate **Colour System** (For the system of each country or region, refer to pages 13, 34).

### Switching off the TV

- 1 Press  on the remote control or on the TV left side panel to switch to the standby mode.

#### Notes:







- When the TV will not be used for a long period of time, such as during vacation or travel, remove the power plug from the wall outlet.
- The TV will automatically turn itself off after approximately 15 minutes if it is tuned to a vacant channel or a station that completes its broadcast for the day. This function does not work in external input or Blue screen Off mode. The TV will automatically turn itself off after approximately 2 hours if you do not operate the TV after turned on by on timer function.
- If power is cut off while you are viewing the TV, the Last Mode Memory function turns on the TV automatically when power is applied again. If power is going to be off for a long time and you are going to be away from your TV, unplug the power cord to prevent the TV from turning on in your absence.

## Tuning the TV for the first time

Before switching on the TV, put your decoder and media recorder to standby, if they are connected, and ensure that the aerial is connected. To setup the TV, use the buttons on the remote control as detailed on page 9.

- 1 Press the  button. The **Quick Setup** screen will appear. This screen will appear the first time that the TV is switched on.





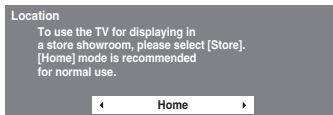

- 2 Press  or  to select the menu language (English, Chinese (CS), Malay, Thai, Vietnamese, Russian, Arabic, Persian or French).
- 3 Press , to display the **Location** menu ( page 14). Press  or  to select **Store** or **Home**. For normal home use, select **Home**.





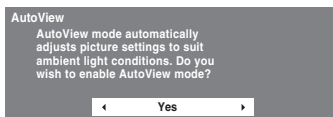

#### Store mode:

**AutoView** menu is not available.

- 4 Press , to display the **AutoView** menu ( page 16). Press  or  to select **Yes** or **No**.



- 5 Press , to display the **Auto Signal Booster** menu ( pages 13), and then  or  to select **Yes** or **No**.

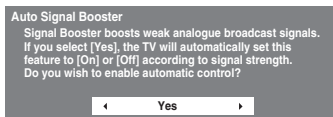

#### Yes mode :

This function performs automatic distinction of On or Off.

- 6 Press , to display the **Auto Tuning** startup screen. Press  to start the automatic search.



When the automatic search is completed, the TV will automatically appear the **Manual Tuning** menu ( page 13).

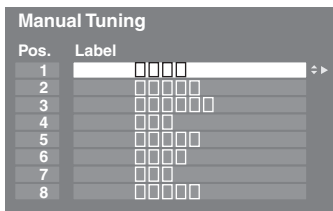

**7** Closing the **Quick Setup** menu, press **EXIT**.

**Note:**

The **Quick Setup** menu can also be display at any time from the **SETUP** menu.

## Using the Quick Menu

Press **QUICK** to display the **Quick Menu** and use  $\nabla$  or  $\triangle$  to select the option.

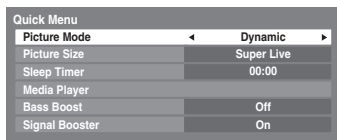

**Note:**

**Quick Menu** items are different depending on the current mode.

Mode	Quick menu item	Description
When viewing a TV programme or pictures from the external input	Picture Mode	page 16.
	Picture Size	page 15.
	Sleep Timer	page 20.
	Media Player	page 27.
	Bass Boost	page 19.
	Signal Booster	page 13.
When using Media Player ( Photo List)	Interval Time	page 28.
	Repeat	page 28.
	Sleep Timer	page 20.
	Interval Time	page 28.
When using Media Player ( Photo Play)	Repeat	page 28.
	Background Music	page 29.
	Play List	page 29.
	Sleep Timer	page 20.
When using Media Player ( Movie List)	Repeat	page 29.
	Sleep Timer	page 20.
When using Media Player ( Movie Play)	Repeat	page 29.
	Play List	page 29.
When using Media Player ( Music List)	Repeat	page 30.
	Sleep Timer	page 20.
When using Media Player ( Music Play)	Repeat	page 30.
	Play List	page 30.
	Sleep Timer	page 20.

## Learning about the menu system

We suggest you familiarize yourself with the display charts before using the menu system:

- Press **MENU** to display menu, then press  $\triangleleft$  or  $\triangleright$  to select main menu headings.
- Press  $\nabla$  or  $\triangle$  to select an item.
- Press  $\triangleleft$  or  $\triangleright$  to select or adjust setting.
- Press **(OK)** to display the next menu.

## Displaying the menu chart

### PICTURE

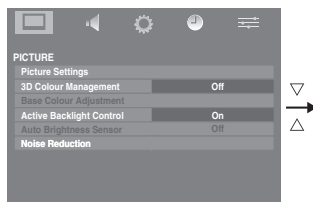

### SOUND

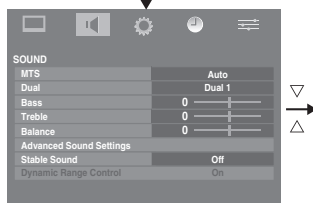

### SETUP



### TIMER

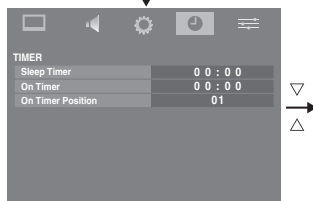

### FUNCTION

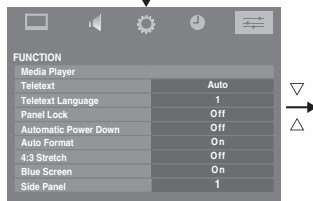

**Notes:**

- In the video input mode (⊖1, ⊖2 and HDMI), **Auto Tuning** and **Manual Tuning** are not available. Instead, **Manual Settings** appears in the **SETUP** menu (see page 14).
- If you connect external equipment via component video source to external input, **Colour System** selection in the **Manual Settings** menu is not available.
- If you do not make a selection for a while, the menu display disappears automatically.
- If you want to close the menu display instantly, press **EXIT** or **MENU**.
- To return to the previous menu, press **RETURN**.
- In the PC input mode, **PC Settings** appears in the **SETUP** menu (see page 27).
- In the 480i, 576i or 1080i input signals mode, you can select the **Cinema Mode** in the **Picture Settings** menu (see page 17).
- When you use the colour management function (see page 18), you can select the **Base Colour Adjustment** in the **PICTURE** menu.
- Ver XXX.XXX in the **SETUP** menu is for service use only.

---

## Watching TV programmes

### Selecting the menu language

Choose from 9 different languages (English, Chinese (CS), Malay, Thai, Vietnamese, Russian, Arabic, Persian or French) for the on-screen display.

- 1 Press **MENU**, then press ◀ or ▶ to display **SETUP** menu.
- 2 Press ▼ or ▲ to select **Language**.
- 3 Press ◀ or ▶ to select the desired language.

### Changing the position

- 1 Enter the desired position number using the **Number** buttons on the remote control. For positions below 10, use 0 and the required number e.g., for position 1.
- 2 You can also change the position by using **P▲** or **P▼**.  
The position will be displayed on the screen with the Mono/Stereo/Dual audio status.

**Note:**

Changing positions between different format channels takes several seconds.

### Switching between two positions

You can switch two positions without entering actual position number each time.

- 1 Select the first position you want to view.
- 2 Select the second position with the **Number** buttons (0-9).
- 3 Press **↔**. The previous channel will be displayed.

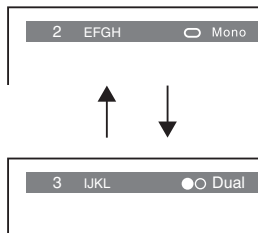

Each time you press **↔**, the TV will switch back and forth between the two positions.

### Displaying the on-screen information

- 1 Press **ⓘ** to display the following on-screen information.

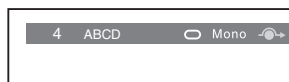

The information will disappear in 6 seconds.

- Position or external input mode selected
- Position skip on/off information
- Label (if set)
- Mono/Stereo/Dual audio status

- 2 To erase the display instantly, press **⊕** again.

---

## Programming channels into the TV's channel memory

- First, use the **Auto Tuning** function to preset all the active channels in your area automatically. Then, arrange the preset channels with the **Manual Tuning** function so that you can tune into only desired channels.
- Use the **Manual Tuning** operation if desired channels cannot be preset with the **Auto Tuning** or if you would like to preset channels to specific position numbers one by one.



## Setting the Location

You can select either **Home** or **Store** mode.

**Home** is recommended for normal home use. Select **Store** when using a TV for displaying in a shop, etc.

- 1 From the **SETUP** menu, press  $\nabla$  or  $\triangle$  to select **Location**.
- 2 Press  $\triangleleft$  or  $\triangleright$  to select **Home** or **Store**.

## Sorting positions

- The TV is capable of receiving a number of different channels depending upon where you live.
- Sorting programme position is an easy way of storing each channel on the programme position of your choice.

Ex.: To swap channel ABCD (Prog.1) for channel MNOP (Prog.4):

- 1 From the **SETUP** menu, press  $\nabla$  or  $\triangle$  to select **Manual Tuning** menu, and then press  $\text{OK}$ .
- 2 Press  $\nabla$  or  $\triangle$  to select the channel **ABCD**, then press  $\triangleright$ .

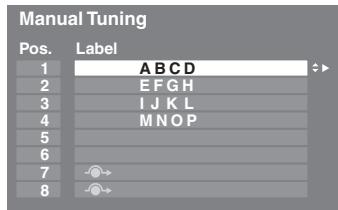

- 3 Press  $\nabla$  to select the new position "4", then press  $\triangleleft$ .
- 4 Press  $\triangle$  to select the channel **MNOP**, then press  $\triangleright$ .
- 5 Press  $\triangle$  to select the new position "1", then press  $\triangleleft$ .
- 6 Confirm new **Manual Tuning** menu.

## Selecting the video input source to view

- 1 Press  $\text{Source}$  on the remote control until the video input mode list appears on the screen, then press  $\nabla$ ,  $\triangle$  or  $\text{Source}$  to select appropriate input source (or press  $\text{Source}$  on the TV left side panel to select required input source directly).

- 2 Press  $\text{OK}$ .  
TV (analogue aerial input),  
VIDEO1 ( $\text{Source}$ (1), standard video input),  
VIDEO2 ( $\text{Source}$ (2) COMPONENT / VIDEO INPUT, standard or component video input),  
HDMI1, HDMI2 (HDMI input),  
PC ( $\text{Source}$  RGB/PC, PC input)

## Setting the Manual Settings menu

- 1 From the **SETUP** menu, press  $\triangleleft$  or  $\triangleright$  to select **Manual Settings**, and then press  $\text{OK}$ .
- 2 Press  $\triangleleft$  or  $\triangleright$  to select an item, and then press  $\nabla$  or  $\triangle$  to select the item as shown below.

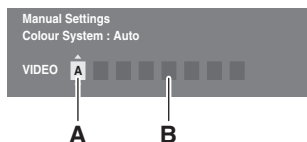

### A. Colour System

Confirm that **Colour System** is set to "A" (Auto). If not, select "A" with  $\nabla$  or  $\triangle$ .

#### Note:

Only standard video signal input, this function is available.

### B. Label

The label allows you to label each input source for your TV.

#### To change or create labels:

- 1) Press  $\nabla$  or  $\triangle$  repeatedly to select a character for the first space, then press  $\triangleleft$  or  $\triangleright$ .

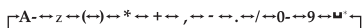

\*(blank space)

- 2) Repeat step 1) to enter the rest of the characters. If you would like a blank space in the label name, you must choose a blank space from the list of characters.

Press  $\text{OK}$  to store your settings.

## Channel List



- 1 Press the **List** button. The **Channel List** will appear.
- 2 Press  $\nabla$  or  $\triangle$  to select a channel, and press  $\text{OK}$  to watch.

## Using the TV's features

### Picture adjustment

- Most of the picture controls and functions are available. However features not available will be greyed out.

### Selecting the Picture Size

1 Press  until the **Picture Size** list appears on the screen, then press  $\nabla$  or  $\Delta$  to select the appropriate **Picture Size** (or press  repeatedly to select the desired **Picture Size** directly).

2 Press .

#### Native

This setting will display the image correctly without distortion or picture clipping.

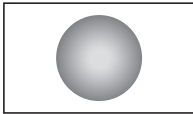

#### Wide

Use this setting when watching a wide-screen DVD, widescreen video tape or a 16:9 broadcast (when available). Due to the range of wide-screen formats (16:9, 14:9, 20:9 etc.), you may see bars on the top and bottom of the screen.

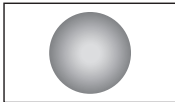

#### 4:3

Use this setting to view a true 4:3 broadcast.

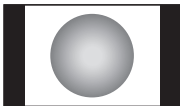

#### Super Live

This setting will enlarge a 4:3 image to fit the screen by stretching the image horizontally and vertically, holding better proportions at the centre of the image. Some distortion may occur.



### Cinema

When watching "all sides panel format" films/video tapes, this setting will eliminate or reduce the black bars on all the sides of the screen by zooming in and selecting the image without distortion.

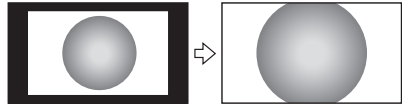

### Subtitle

When subtitles are included on a letterbox format broadcast, this setting will raise the picture so that the most of text is displayed.

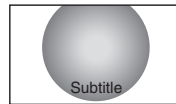

### 14:9

Use this setting when watching a 14:9 broadcast.



### PC Normal

Use this setting for PC connected via HDMI or RGB/PC terminal when receiving PC signal format. This setting will display the image correctly without distortion or picture clipping.

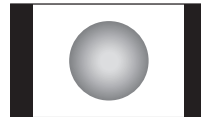

### PC Wide

Use this setting for PC connected via HDMI or RGB/PC terminal when receiving PC signal format. This setting will display the image without picture clipping.

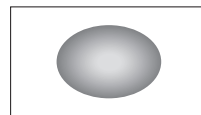

### Dot by Dot

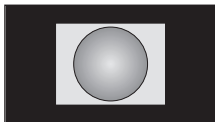

"Dot by Dot" is a non-scaling display. Depending on the input signal format, the picture is displayed with side panels and/or bars at the top and bottom (i.e. VGA input source).



#### Notes:

- In the PC connected via HDMI or RGB/PC terminal (see page 26), the picture size selection is **PC Wide**, **PC Normal** or **Dot by Dot** only.
- Using the special functions to change the size of the displayed image (e.g. changing the height/width ratio) for the purpose of public display or commercial gain may infringe on copyright laws.
- If the aspect ratio of the selected format is different from the one of the TV transmission or video programme, it can cause a difference in vision. Change to the correct aspect ratio picture size.
- When using the PC connected via HDMI or RGB/PC terminal, the moving image quality may be deteriorated.

### Using the picture still

- Press  to freeze the picture. Even if an image is frozen on the TV screen, the pictures are running on the input source. Audio continues to be output as well. To return to a moving picture, press  again.

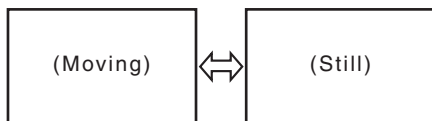

#### Note:

If you use this function except for the purpose of your private viewing and listening, it may infringe the copyright protected by the copyright laws.

### Adjusting the Picture Position

Adjustment to the position of the picture may be made to suit your viewing preferences.

- 1 From the **SETUP** menu, press  $\nabla$  or  $\Delta$  to select **Picture Position**.
- 2 Press , then press  $\nabla$  or  $\Delta$  to select the item you want to adjust.

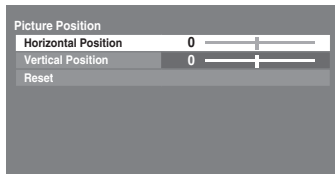

- 3 Press  $\triangleleft$  or  $\triangleright$  to adjust the settings as desired.



#### Notes:

- When the picture size is in Wide or 4:3 mode, only the Horizontal position can be adjusted.
- When the picture size is in **Native**, **PC Wide**, **PC Normal** and **Dot by Dot** mode, none of this function will be available.

### Resetting the Picture Position

This function resets your **Picture Position** settings to the factory settings.

- 1 From the **Picture Position** menu, press  $\nabla$  or  $\Delta$  to select **Reset**.
- 2 Press .

### Activating the Picture Mode

This TV offers the choice of personalising the picture style.

**AutoView**, **Dynamic**, **Standard**, **Mild**, **Movie**, **Eco Mode 1**, **Eco Mode 2**, **Game** and **PC** are preset options and affect many features/settings within the TV.

#### Notes:

- Because the **AutoView** mode automatically adjusts picture settings based on ambient light conditions, the **Auto Brightness Sensor** is greyed out when it is selected.
- If using **Eco Mode 1** or **Eco Mode 2** will be changed the dark screen, and you will be able to reduce power consumption. The **Eco Mode 2** is effect better than the **Eco Mode 1**. The **Backlight** mode is not available in the **Eco Mode 1** or the **Eco Mode 2**.
- **Game** mode is available in external input mode (other than aerial input). When you select **Game** mode, suitable widescreen formats will be selected.
- **PC** mode is available in RGB/PC input mode or HDMI input mode.

- 1 From the **PICTURE** menu, press  $\nabla$  or  $\Delta$  to select **Picture Settings**.

- Press **OK**, then press  $\nabla$  or  $\triangle$  to select **Picture Mode**.

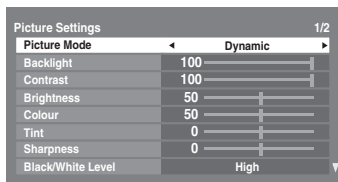

- Press  $\triangleleft$  or  $\triangleright$  to select the picture mode you prefer and press **OK**.

## Activating the picture preferences

You can customise current picture mode settings as desired. For example, while selecting "Dynamic," if you change the following items, such as **Picture Settings** items, your new setting is saved as **Dynamic-user**.

- From the **Picture Settings** menu, press  $\nabla$  or  $\triangle$  to select either **Backlight**, **Contrast**, **Brightness**, **Colour**, **Tint** or **Sharpness** and press **OK**.
- Press  $\triangleleft$  or  $\triangleright$  to adjust the settings.

## Setting the Black/White Level

**Black/White Level** improves the contrast of the picture.

- From the **Picture Settings** menu, press  $\nabla$  or  $\triangle$  to select **Black/White Level**.
- Press  $\triangleleft$  or  $\triangleright$  to select **High**, **Off**, **Low** or **Middle**.

## Using the Cinema Mode

A movie film's picture runs at 24 frames a second, whereas movie software such as DVD, etc., that you enjoy watching on TV at home runs at 30 (NTSC) or 25 (PAL) frames a second. To convert this signal to reproduce a smooth motion and picture quality, select the **On** mode.

### Effective signal and setup conditions:

- When the Video input mode is selected.
- When the input signal format is 480i, 576i or 1080i signals.

- From the Picture Settings menu, press  $\nabla$  or  $\triangle$  to select **Cinema Mode** on the 2nd page.



- Press  $\triangleleft$  or  $\triangleright$  to select **On** or **Off**.

### Note:

When a DVD movie with subtitle is playing back, this mode may not work correctly.

## Adjusting the Colour Temperature

**Colour Temperature** increases the warmth or coolness of the picture by setting the red, green or blue tint.

- From the **Picture Settings** menu, press  $\nabla$  or  $\triangle$  to select **Colour Temperature** on the 2nd page, then press **OK**.
- Press  $\triangleleft$  or  $\triangleright$  to select **Cool**, **Natural**, or **Warm** to suit your preference.

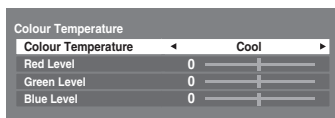

- Press  $\nabla$  or  $\triangle$  to select **Red Level**, **Green Level** or **Blue Level**, then press  $\triangleleft$  or  $\triangleright$  to adjust the setting as required.

## Resetting the Picture Settings

- From the **Picture Settings** menu, press  $\nabla$  or  $\triangle$  to select **Reset** on the 2nd page, then press **OK**.

## Activating the Noise Reduction (NR)

If the receiving signal of MPEG is a mosquito (grained) noise depending on the compression and conversion, the picture is weak and the picture is blurry, the picture may be improved when using this function.

- From the **PICTURE** menu, press  $\nabla$  or  $\triangle$  to select **Noise Reduction**, and then press **OK**.



- Press  $\nabla$  or  $\triangle$  to select **Auto NR**, and then press  $\triangleleft$  or  $\triangleright$  to select **On** or **Off**.

### Off mode :

**MPEG NR** menu and **DNR** menu are available.

- MPEG NR** mode: **Low**, **Middle**, **High** or **Off**
- DNR** (Digital Noise Reduction) mode: **Low**, **Middle**, **High** or **Off**

### Note:

*DNR function is available for 480i and 576i signals.*

## Adjusting the Colour Management

You can adjust the picture colour quality by selecting from 6 base colour adjustments : **Red**, **Green**, **Blue**, **Yellow**, **Magenta** or **Cyan**.

- From the **PICTURE** menu, press  $\nabla$  or  $\Delta$  to select **3D Colour Management**.
- Press  $\triangleleft$  or  $\triangleright$ , then press  $\triangleleft$  or  $\triangleright$  to select **On**.
- Press  $\odot$ , then press  $\nabla$  or  $\Delta$  to select **Base Colour Adjustment**.
- Press  $\odot$ , then press  $\nabla$  or  $\Delta$  to select an item you want to adjust.

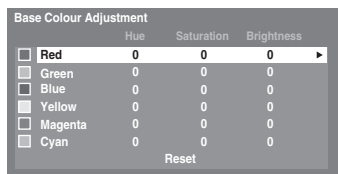

- Press  $\triangleright$ , then press  $\triangleleft$  or  $\triangleright$  to select **Hue**, **Saturation** or **Brightness**.
- Press  $\nabla$  or  $\Delta$  to adjust the settings as required.



## Resetting the Base Colour Adjustment

The reset function adjusts the base colour adjustment to the factory settings.

- From the **Base Colour Adjustment** menu, press  $\nabla$  or  $\Delta$  to select **Reset**.
- Press  $\odot$ .

## Using the Active Backlight Control

In order to improve screen visibility, the **Active Backlight Control** sets the screen brightness automatically during dark scenes.

- From the **PICTURE** menu, press  $\nabla$  or  $\Delta$  to select **Active Backlight Control**.
- Press  $\triangleleft$  or  $\triangleright$  to select **On** or **Off**.

## Activating Auto Brightness Sensor

When the **Auto Brightness Sensor** is activated, it will automatically optimise the backlighting levels to suit ambient light conditions.

- From the **PICTURE** menu, press  $\nabla$  or  $\Delta$  to select **Auto Brightness Sensor**.

- Press  $\triangleleft$  or  $\triangleright$  to select **On** or **Off**.

## Sound adjustment

### Setting the MTS (Multi-channel TV Sound)

#### Auto mode

The **MTS Auto** mode automatically recognize stereo/bilingual programmes depending on the broadcast signal.

- Press **MENU**, and then press  $\triangleleft$  or  $\triangleright$  to display the **SOUND** menu.
- Press  $\nabla$  or  $\Delta$  to select **MTS**, and then press  $\triangleleft$  or  $\triangleright$  to select **Auto** or **Mono**.

#### Mono mode

If you experience noise or poor reception of any stereo/bilingual programme, set the **MTS** mode to **Mono**.

Noise will be reduced and reception may improve.

#### Note:

*If you experience noise with a particular programme on whose channel reception is usually good, try setting MTS mode to **Auto**, then switch  $\odot$  to  $\square$  Mono (monaural).*

## Selecting the Dual 1 or Dual 2 mode

You can hear only **Dual 1** or **Dual 2** sound selected, whenever bilingual programmes are received.

- Press **MENU**, and then press  $\triangleleft$  or  $\triangleright$  to display the **SOUND** menu.
- Press  $\nabla$  or  $\Delta$  to select **Dual**, and then press  $\triangleleft$  or  $\triangleright$  to select **Dual 1** or **Dual 2**.

#### Notes:

- When the MTS setting is in **Mono** mode, the **Dual** menu is not selectable.
- The **Dual** menu setting status remains even if the TV is turned off.

## Selecting the stereo programmes

- When a stereo programme is received,  $\odot$  **Stereo** appears.



- Press  $\odot$  to select the stereo/monaural mode.  $\odot$  **Stereo** and  $\square$  **Mono** appear cyclically on the screen.

 Stereo

## Selecting the bilingual programmes

- 1 When a bilingual programme is received,  **Dual** appears.
- 2 Press  to select the sound to be heard. The sound differs according to the transmission system: NICAM or German stereo/bilingual broadcast.

Display	Sound to be heard	
	NICAM	German stereo/ bilingual broadcast
<input checked="" type="radio"/> Dual 1	Sub I sound	Main sound
<input checked="" type="radio"/> Dual 2	Sub II sound	Sub sound
<input type="radio"/> Mono	Main sound	—

### Note:

These settings are not stored in the TV memory.

## Selecting the monaural programmes

If sound distortion, interruptions or silence arises in the low sound volume level, setting the  **Mono 2** mode will mitigate the problem.

- 1 When a monaural programme is received,  **Mono** appears.
- 2 Press  to select a monaural mode that is easy to hear.  **Mono 1** and  **Mono 2** appear cyclically to the screen.

### Note:

On some cases, the reception of stereo/bilingual broadcasts may not be possible after switching on the  **Mono 2** mode.

## Adjusting the sound quality

- 1 From the **SOUND** menu, press  $\nabla$  or  $\Delta$  to select an item you want to adjust.
- 2 Press  $\triangleleft$  or  $\triangleright$  to adjust the settings as required.

Selection	$\triangleleft$	Pressing	$\triangleright$
Bass	weaker		stronger
Treble	weaker		stronger
Balance	decreases the right channel		decreases the left channel

## Using the Advanced Sound Settings

**Bass Boost** helps to create rich bass.

**Voice Enhancement** helps to emphasize dialogue. It will be easier to hear voices over other background audio.

- 1 From the **SOUND** menu, press  $\nabla$  or  $\Delta$  to select **Advanced Sound Settings**, and then press .
- 2 Press  $\nabla$  or  $\Delta$  to select the item you want to adjust.



**Voice Enhancement** : To turn the vocal emphasis effect **On** or **Off**.

**Bass Boost** : To select the desired bass expansion level **On** or **Off**.

## Using the Stable Sound

The **Stable Sound** function limits the highest volume level to prevent extreme changes in volume when the signal source changes (for example, to prevent the sudden increase in volume that often happens when a TV programme switches to a commercial).

- 1 From the **SOUND** menu, press  $\nabla$  or  $\Delta$  to select **Stable Sound**.
- 2 Press  $\triangleleft$  or  $\triangleright$  to select **On** or **Off**.

### Note:

The **Stable Sound** effect is active only when the sound outputs from the speaker.

## Dynamic Range Control

This feature allows control of compression for digital audio signal excluding those with MPEG-1 and MPEG-2 audio.

- 1 From the **SOUND** menu, press  $\nabla$  or  $\Delta$  to select **Dynamic Range Control**.
- 2 Press  $\triangleleft$  or  $\triangleright$  to select **On** or **Off**.

## Setting the Digital Audio Output

- 1 From the **SETUP** menu, press  $\nabla$  or  $\Delta$  to select **AV Connection**, and then press .
- 2 Press  $\nabla$  or  $\Delta$  to select **Digital Audio Output**.

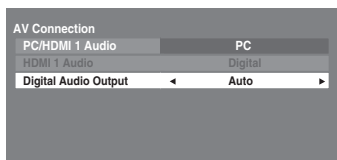

- 3** Press ◀ or ▶ to select **Auto** or **PCM**
- Auto:** This mode outputs Dolby Digital or PCM to the digital audio output socket providing it is being broadcast.
- PCM:** Select this when a 2ch digital stereo amplifier is connected to the TV. When you select a Dolby Digital or MPEG audio track, the sound is converted to the PCM (2ch) format and output.

## Other features settings

### Selecting the TIMER menu

The Timer is especially useful if you want the TV to turn itself on or off after a selected period of time.

- 1** Press **MENU**, and then press ◀ or ▶ to display the **TIMER** menu.
- 2** Press ▼ or ▲ to select the required timer mode (**Sleep Timer** (Turn off the TV) or **On Timer**).
- 3** Press the **Number** buttons (0-9), ◀ or ▶ to set the On or Off delay time. The timer display will set by 10 minutes, up to 12 hours and 50 minutes.
- 4** When setting the On timer, press ▼ or ▲ to select the **On Timer Position** and enter the program position number you want to watch. Press **EXIT** to exit the menu. Set the Standby mode by pressing ⏻ on the remote control.

**Note:**

The TV will automatically turn itself off after approximately 2 hours if you do not operate the TV after turned on by on timer function.

### Using the Auto Format

When the TV receives a true HDMI signal picture and the **Auto Format** is **On**, it will automatically be displayed in HDMI signal format, irrespective of the TV's previous setting.

- 1** Press **MENU**, then press ◀ or ▶ to display the **FUNCTION** menu.
- 2** Press ▼ or ▲ to select **Auto Format**, then press ◀ or ▶ to select **On** or **Off**.

### Activating Blue Screen

With the **Blue Screen** function **On**, the screen will automatically turn blue and the sound will be muted (except for PC input) when no signal is being received.

- 1** From the **FUNCTION** menu, press ▼ or ▲ to select **Blue Screen**.
- 2** Press ◀ or ▶ to select **On** or **Off**.

**Note:**

In the **PC input mode** or **Teletext mode**, this function is not available.

### Setting the Automatic Power Down

The TV will automatically turn itself off (standby) after approximately 4 hours, if you don't touch the control buttons on the remote control or on the TV control panel.

- 1** From the **FUNCTION** menu, press ▼ or ▲ to select **Automatic Power Down**.
- 2** Press ◀ or ▶ to select **On** or **Off**.

### Panel Lock

**Panel Lock** disables the buttons on the TV. All buttons on the remote control can still be used.

- 1** From the **FUNCTION** menu, press ▼ or ▲ to select **Panel Lock**.
- 2** Press ◀ or ▶ to select **On** or **Off**.

**Note:**

When **Panel Lock** is **On**, a reminder will appear when the buttons on the TV are pressed. If the standby button is pressed, the TV will switch off and can only be brought out of standby by using the remote control.

### Activating the 4:3 Stretch

When **4:3 Stretch** is activated, this function will switch 4:3 format programmes into a full screen picture.

- 1** From the **FUNCTION** menu, press ▼ or ▲ to select **4:3 Stretch**.
- 2** Press ◀ or ▶ to select **On** or **Off**.

**Note:**

In **HDMI signal format**, this function is available.

### Adjusting the brightness of Side Panel

You can adjust the brightness of **Side Panel** in 14:9 or 4:3, etc. mode.

- 1** From the **FUNCTION** menu, press ▼ or ▲ to select **Side Panel**.

- Press ◀ or ▶ to adjust the settings as required.

## Teletext

This TV has a multi-page Teletext memory, which takes a few moments to load and it offers two ways of viewing **Teletext Auto** and **List** which are explained below.

### Setting up the Teletext mode

#### To select a language for Teletext:

The language 1-4 option enables the display of different language when using **Teletext**.

- From the **FUNCTION** menu, and then press ▼ or ▲ to select **Teletext Language**.
- Press ◀ or ▶ to select the required language.

- **Language 1:** English, German, Dutch, Flemish, Russian, Bulgarian, Ukranian, Lettish, Lithuanian, Czech, Slovak, Estonian
- **Language 2:** Polish, German, Dutch, Flemish, Estonian, Lettish, Lithuanian, French, Serbian, Croatian, Slovenian, Czech, Slovak, Rumanian
- **Language 3:** English, French, Hebrew, Turkish, Arabic
- **Language 4:** English, French, Hebrew, Turkish, Farsi (Iranian/Persian)

#### To select Teletext mode:

Select a channel position with the desired Teletext service.

- From **FUNCTION** menu, press ▼ or ▲ to select **Teletext**.
- Press ◀ or ▶ to select **Auto** or **List** mode.

#### Note:

When you are watching the teletext programme, **SETUP** menu and **FUNCTION** menu are not selectable.

## Teletext general information

### (TEXT) button:

Pressing (TEXT) once will bring up the teletext screen. Press again to superimpose the teletext over a normal broadcast picture. Press again to return to normal TV mode. You need to return to normal viewing if you wish to change channels. When you first press (TEXT) to access the text service, the first page you see will be the initial page.

In **Auto** mode, this displays the main subjects available and their relevant page numbers. In **List** mode, you will see the page numbers currently stored on the **each colour** button.

#### Note:

If you press (TEXT) while the Picture Mode is activated, this mode will be cancelled.

#### Sub-pages:

Once in this chosen page, if there are sub-pages they will automatically load into memory without changing the one you are reading. If there are many sub-pages, it will take a long time for them all to load and this will depend on the speed with which the broadcaster transmits them.

To access the sub-pages in memory, press ◀ or ▶ to view them.

## Using Subtitles

- Press (SUBTITLE) on the remote control to display the current Subtitle status. While this status is displayed, press again to change the setting.

#### Note:

If **Subtitle** is On, the TV will always display subtitles whenever such information is available for the channel you are viewing.

## Using Auto mode

There are two Modes: **Auto** will display FASTEXT, if available. **List** will display your four favorite pages. In either mode, as an alternative to the coloured buttons, you can access a page by entering a 3-digit number, using the **Number** buttons on the remote control, or to advance to the next page, press P^, to go back to the previous page press P~. To change between **Auto** and **List**, see above.

- Press (TEXT) to access teletext.

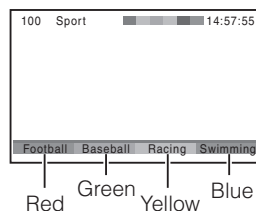

If FASTEXT is available, you will see 4 coloured titles at the base of the TV screen. To access any given subject, simply press the relevant coloured button on the remote control.

If FASTEXT is not available, you can access any page simply by entering a 3-digit page number or pressing the corresponding coloured button.

For further information on your particular text system(s), see the broadcast teletext index page or consult your local Toshiba dealer.

## Using List mode

- 1 Press **TEXT** to access teletext.

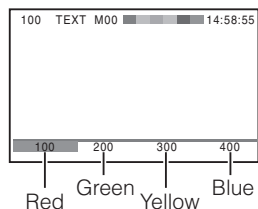

The four choices at the bottom of the screen are now number – **100, 200, 300** and **400**, which have been programmed into the TV's memory.

- 2 To view these pages, use the coloured prompt buttons.  
e.g. press the Green button to view page 200.
- 3 If you want to change these stored pages, press the coloured button for the colour you want to change.  
e.g. Press the Green button and enter the 3-digit number.  
This number will change and blinking.
- 4 Press **OK** to store your choice. The bars at the bottom of the screen will flash white.
- 5 You may view other pages by simply entering the 3-digit page number – but NEVER press **OK** or you will lose the favorite already stored.

## Teletext buttons on the remote control

Below is an introduction to the teletext buttons on your remote control and their functions.

### **TEXT** To display a page of teletext:

Press **TEXT** to display teletext. Press again to superimpose the teletext over a normal broadcast picture. Press again to return to normal TV mode.

### **INDEX** To display an index/initial page:

#### In Auto-mode

Press **INDEX** to access the index page. The one displayed is dependant on the broadcaster.

#### In List-mode

Press **INDEX** to return to the 100 page or initial page.

### **REVEAL** To reveal concealed text:

Some pages cover topics such as quizzes and jokes. To discover the solutions, press **REVEAL**.

### **WANTED** To hold a wanted page:

This function is included as it is part of the broadcast teletext system but you will not need it as this TV allows you to control the display of sub-pages.

### **ENLARGE** To enlarge the teletext display size:

Press **ENLARGE** once to enlarge the top half of the page, press again to enlarge the bottom half of the page. Press again to revert to the normal size.

### **PICTURE** To select a page while viewing a normal picture:

When in teletext mode, if a page selection is made and then **PICTURE** is pressed, a normal picture will be displayed. The TV will indicate when the page is present by displaying the title bar of the text page at the top of the screen. Press **TEXT** to view the page.

#### Note:

*It will not be possible to change programme position while in Teletext mode, you will have to cancel the teletext first by pressing **TEXT** to return to a normal TV picture.*

### To select the time display:

If you press **PICTURE** while watching a normal TV broadcast, you will see a time display from the broadcaster. It will remain on the screen for about 5 seconds.

9:56 and 25 seconds p.m.



# Connecting your TV

## Back connections

### Connection example

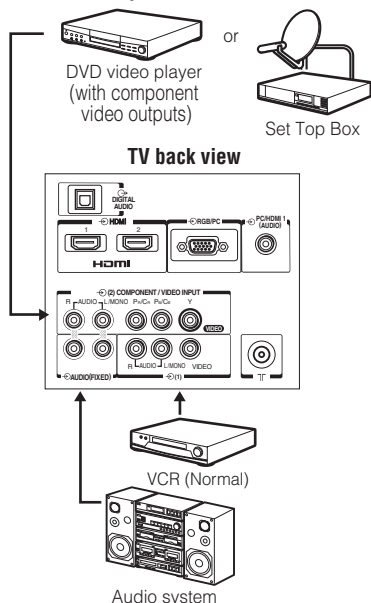

- Before connecting any external equipment, turn off all main power switches.
- The unauthorized recording of TV programmes, DVDs, video tapes and other materials may infringe upon the provisions of copyright law.
- The **COMPONENT VIDEO INPUT** consists of three component video signals (**Y**, **P<sub>B</sub>/C<sub>B</sub>**, **P<sub>R</sub>/C<sub>R</sub>**) and provides the best picture performance. These terminals can only be used with the component video compatible equipment e.g. DVD video player, etc.
- If you connect to COMPONENT VIDEO for the **COMPONENT / VIDEO INPUT** terminals, screen display will appear changes to **COMPONENT**.
- Additional equipment and cables shown are not supplied with this TV.

#### Note:

⊖(2) COMPONENT / VIDEO INPUT terminals  
**Standard video mode:**  
 Use terminals Y, L and R.

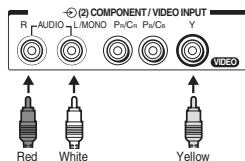

#### Component video mode:

Use terminals Y, P<sub>B</sub>/C<sub>B</sub>, P<sub>R</sub>/C<sub>R</sub>, L and R.

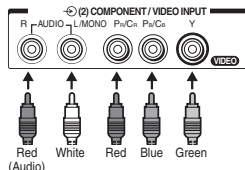

## Connecting an audio system

You can enjoy high quality dynamic sound by connecting the TV to an audio system.

#### Notes:

- **DO NOT** connect the **DIGITAL AUDIO** output terminal to the AC-3 RF input of a Dolby Digital Receiver with a built-in Dolby Digital decoder.
- Connect the **DIGITAL AUDIO** output terminal to the **OPTICAL** input of a receiver or processor.
- Refer to the owner's manual of the connected equipment as well.
- When you connect the TV to other equipment, be sure to turn off the power and unplug all of the equipment from the wall outlet before making any connections.
- The output sound of the TV has a wide dynamic range. Be sure to adjust the audio amplifier's volume to a moderate listening level before turning on the power. Otherwise, the speakers and your hearing may be damaged by sudden high volume audio.
- Turn off the amplifier before you connect or disconnect the TV's power cord. If you leave the amplifier power on, the speakers may be damaged.

#### Warning:

When you are connecting (via the **DIGITAL AUDIO** output terminal) an AV decoder that does not have Dolby Digital decoding function, be sure to set **PCM** for Digital Output menu (ⓘ page 19). Otherwise, the speakers and your hearing may be damaged by sudden high volume audio.

### Connecting an amplifier equipped with a Dolby Digital decoder

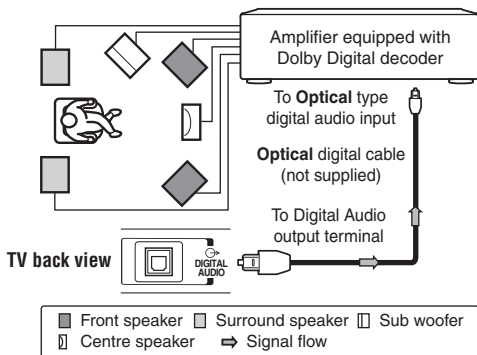

You can enjoy dynamic realistic sound by connecting the TV to an amplifier equipped with a Dolby Digital decoder or Dolby Digital processor. When using this setup, select **Auto** in the Digital Output menu.

### Connecting an amplifier equipped with a digital audio (optical) input

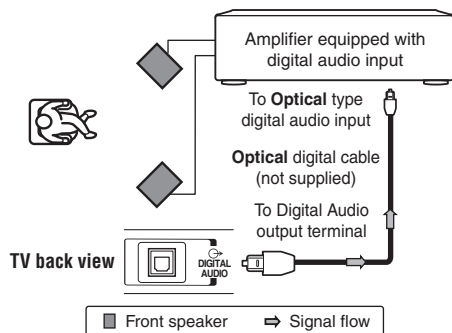

You can enjoy the dynamic sound of a 2-channel digital stereo by connecting the TV to an amplifier equipped with a digital audio (optical) input and speaker system (right and left front speakers). When using this setup, select **PCM** in the Digital Output menu (page 19).

### Connecting HDMI or DVI devices

- When turning on your electronic components, turn on the TV first, and then the HDMI and DVI device.
- When turning off your electronic components, turn off the HDMI and DVI device first, and then the TV.

- This TV may not be compatible with features and/or specifications that may be added in the future.
- This TV is only operable with L-PCM and Dolby Digital on 32/44.1/48 kHz. If there is no sound when using HDMI, use the analogue audio cables to connect the TV and the HDMI device, and select **Analogue** in **HDMI 1 Audio** of the **AV Connection** menu.
- This TV is able to connect with HDMI devices. But it is possible that some HDMI devices may not operate properly with this TV.

### Connecting an HDMI or a DVI device

The HDMI input on your TV receives digital audio and uncompressed digital video from an HDMI device and uncompressed digital video from a DVI device.

This input is designed to accept HDCP programme material in digital from CEA-861-D compliant consumer electronic devices (such as a set top box and DVD player with HDMI and DVI output).

The HDMI input is designed for best performance with 1080i (50 Hz/60 Hz) and 1080p (24/50/60 Hz) high-definition video signals, but will also accept and display 480i, 480p, 576i, 576p, and 720p (50Hz/60 Hz) and VGA (VESA 640 × 480 @ 60/72/75 Hz) signals.

- HDMI: High-Definition Multimedia Interface
- DVI: Digital Video Interface
- HDCP: High-bandwidth Digital Content Protection
- CEA-861-D compliance covers the transmission of uncompressed digital video with high-bandwidth digital content protection, which is being standardized for reception of high-definition video signals. Because this is an evolving technology, it is possible that some devices may not operate properly with the TV.
- Acceptable PC signal format:
  - S-VGA: VESA 800 × 600 @ 56/60/72/75 Hz
  - XGA: VESA 1024 × 768 @ 60/70/75 Hz
  - W-XGA: VESA 1280 × 768 @ 60/75 Hz
  - W-XGA: VESA 1360 × 768 @ 60 Hz
  - S-XGA: VESA 1280 × 1024 @ 60/75 Hz

However, these signal formats are converted to match the number of pixels of the LCD panel. Therefore, the TV may not display small text properly.

If you connect this unit to your PC, the compressed image is displayed in S-XGA mode, therefore the picture quality may deteriorate and characters may not be read.

- L-PCM: Linear-Pulse Code Modulation.
- Supported Audio format: L-PCM, Dolby Digital, sample rate 32/44.1/48 kHz

## Connecting an HDMI device

One HDMI cable (type A connector)

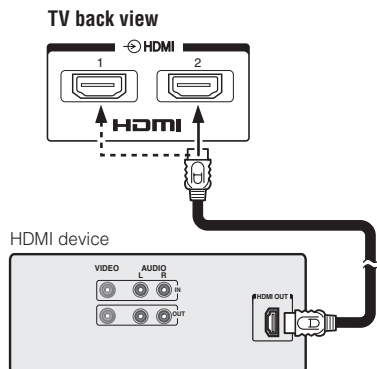

For proper operation, it is recommended that you use a short HDMI cable.

HDMI cable transfers both video and audio.

## Connecting a DVI device

One HDMI (type A connector)-to-DVI adapter cable and audio cables

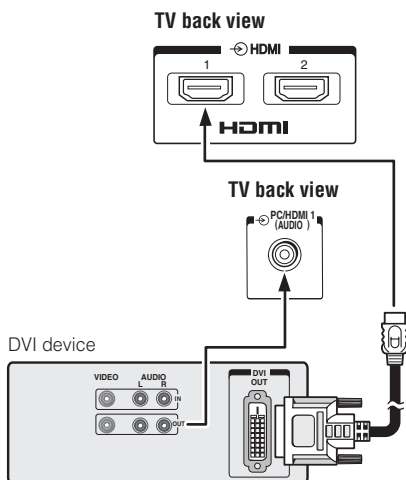

### HDMI (type A connector)-to-DVI adapter cable

For proper operation, the length of an HDMI-to-DVI adapter cable should not exceed 3m. The recommended length is 2m.

### Standard analogue audio cables

An HDMI-to-DVI adapter cable transfers only video. Separate analogue audio cables are required.

## Selecting the PC/HDMI 1 Audio mode

You can select PC audio or HDMI audio when using this function.

- 1 From the **SETUP** menu, and then press  $\nabla$  or  $\triangle$  to select **AV Connection**.
- 2 Press **OK** to display the **AV Connection** menu.

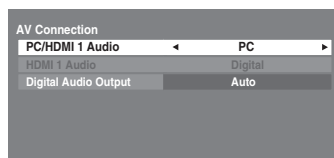

- 3 Press  $\nabla$  or  $\triangle$  to select **PC/HDMI 1 Audio**, then press  $\triangleleft$  or  $\triangleright$  to select **PC** or **HDMI1**.

## Setting the HDMI 1 Audio mode

You can select sound of an HDMI or DVI device connected to the HDMI input terminals from three modes:

**Auto, Digital or Analogue.**

### Note:

*This function is available only when the **PC/HDMI 1 Audio** mode is set to **HDMI1**.*

- 1 From the **AV Connection** menu, press  $\nabla$  or  $\triangle$  to select **HDMI 1 Audio**.
- 2 Press  $\triangleleft$  or  $\triangleright$  to select **Auto**, **Digital** or **Analogue**.

## Connecting a computer

### To connect a PC to the RGB/PC terminal on the TV:

An analogue RGB (15 pin) computer cable can be connected.

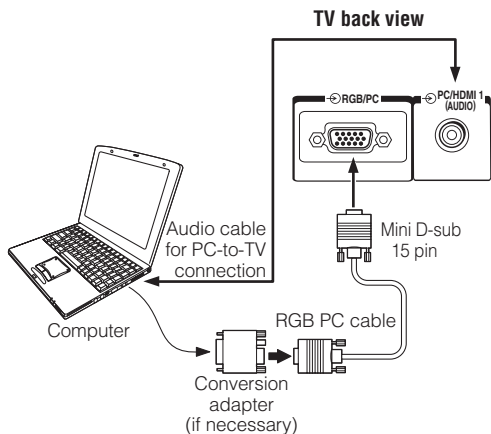

Connect a PC cable from the computer to the **RGB/PC** terminal on the back of the TV.

### The following signals can be displayed:

- VGA: VESA 640 × 480 @ 60/72/75 Hz
- S-VGA: VESA 800 × 600 @ 56/60/72/75 Hz
- XGA: VESA 1024 × 768 @ 60/70/75 Hz
- W-XGA: VESA 1280 × 768 @ 60/75 Hz
- W-XGA: VESA 1360 × 768 @ 60 Hz
- S-XGA: VESA 1280 × 1024 @ 60/75 Hz

### Notes:

- Some PC models cannot be connected to this TV.
- If connecting a certain PC model that signal is particular, the PC signal may not be detected correctly.
- There is no need to use an adapter for computers with DOS/V compatible mini D-sub 15 pin terminal.
- A bar may appear in the upper, lower, right or left side of the screen, or parts of the picture may be obscured depending on some signals. This is not the malfunction.
- If the edges of the picture are stretched, readjust the picture position adjustments in the **PC Settings** menu.
- Depending on the specification of the PC you are playing the DVD-Video on, and the DVD's title, some scenes may be skipped, or you may not be able to pause during multi-angle scenes.

### To connect a PC to the HDMI terminal on the TV:

When connecting a PC to the HDMI terminal on the TV, use an HDMI-to DVI adapter cable and analogue audio cables.

If connecting a PC with an HDMI terminal, use an HDMI cable (type A connector). Separate analogue audio cables are not necessary.

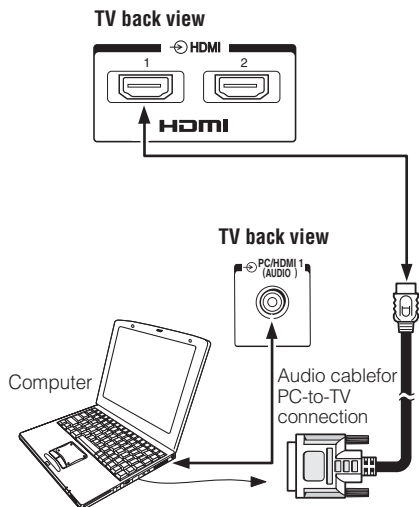

### Notes:

- The edges of the images may be hidden.
- If connecting a certain PC model that signal is particular, the PC signal may not be detected correctly.



### Signal names for mini D-sub 15 pin connector

Pin assignment for RGB/PC terminal



Pin No.	Signal name	Pin No.	Signal name
1	R	9	NC
2	G	10	Ground
3	B	11	NC
4	NC (not connected)	12	NC
5	NC	13	H-sync
6	Ground	14	V-sync
7	Ground	15	NC
8	Ground		

## Using the PC Settings

- Most of the picture controls and functions are available. However features not available will be greyed out.
- First press  until the video input mode list appears on the screen, then press  $\nabla$  or  $\triangle$  and  in order to select the PC input mode ( page 14).
- This function may not be available for some signal or if no signal is received.
- The optimum points of the **Clock Phase** and **Sampling Clock** adjustments may be incomprehensible according to the input signals.

### Adjusting the picture position

- 1 Press **MENU**, then press  $\triangleleft$  or  $\triangleright$  to display the **SETUP** menu.
- 2 Press  $\nabla$  or  $\triangle$  to select **PC Settings**.
- 3 Press  to display the **PC Settings** menu.

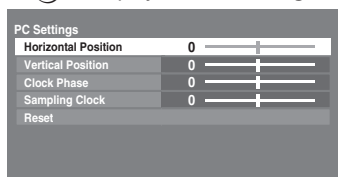

- 4 Press  $\nabla$  or  $\triangle$  to select an option you want to adjust. Press  $\triangleleft$  or  $\triangleright$  to adjust the settings as required.

### Adjusting the Clock Phase of the picture

If the **Clock Phase**, which synchronize the PC signal and LCD display, is not optimized, the picture will blur.

This function enables you to adjust **Clock Phase** and display a clear picture.

- 1 From the **PC Settings** menu, press  $\nabla$  or  $\triangle$  to select **Clock Phase**.
- 2 Press  $\triangleleft$  or  $\triangleright$  to obtain a clear picture.

### Adjusting the Sampling Clock

If the **Sampling Clock** does not match with the dot clock frequency of the PC, blurred picture detail will occur, or screen width will change, or drift patterns in vertical lines may be apparent. This function enables you to adjust it and optimize the picture.

- 1 From the **PC Settings** menu, press  $\nabla$  or  $\triangle$  to select **Sampling Clock**.
- 2 Press  $\triangleleft$  or  $\triangleright$  to optimize the picture.

## Resetting the PC Settings

The **Reset** function adjusts the **PC Settings** to the factory settings.

- 1 From the **PC Settings** menu, press  $\nabla$  or  $\triangle$  to select **Reset**.
- 2 Press .

#### Note:

When a PC is connected using HDMI none of these function will be available.

## Using the Media Player

This TV allows you to enjoy movie, music (MP3) and photo files stored on a USB device

#### Note:

Do not insert/remove USB device while in use.

## Media Player Specifications

Interface version: USB 2.0

USB class: Mass Storage

File System: FAT16 and FAT32

Maximum memory size: Unlimited

#### Notes:



- Connectivity is not guaranteed for all devices.
- USB Hub will not be properly operated.

You must obtain any required permission from copyright owners to download or use copyrighted content. TOSHIBA cannot and does not grant such permission.

## Basic operation

When Auto Start is enabled, you will be asked if you want to start the Media Player whenever a USB device is inserted. If Auto Start is disabled, you must manually start the Media Player from the menu.

### Setting the Auto Start:

- 1 From the **FUNCTION** menu, press  $\nabla$  or  $\triangle$  to select **Media Player**, and then press .
- 2 Press  $\nabla$  or  $\triangle$  to select **Setup**, and press .
- 3 Press  $\nabla$  or  $\triangle$  to select **Auto Start**, and then press  $\triangleleft$  or  $\triangleright$  to select **On** or **Off**.





### Notes:

- During Single View and Slide Show, you can display a photo list on the screen from the **Play List** in the **Quick Menu**, and then press  $\nabla$  or  $\triangle$  to select a list as desired.
- During Signal View and Slided Show, press **QUICK**, and then press  $\nabla$  or  $\triangle$  to select **Background Music**. Select **On**, you can listen to music stored in the same folder.

### Closing the Photo Viewer

- 1 Press **EXIT**. The TV will return to the last viewed channel or external input.

### File Compatibility

USB device use, see page 31.

### Viewing movie files

You can select movies from a list of available files.

- 1 When it is displayed the Multi View, press  $\nabla$ ,  $\triangle$ ,  $\triangleleft$  or  $\triangleright$  to select a file or folder. P $\nabla$  or P $\triangleleft$  buttons can be used to page up/down the movie list when there are more files than will fit onto one screen.
- 2 When you select a folder, press  $\text{OK}$  to move to the next layer. Select **Up Folder** to move back to the previous layer.
- 3 With the desired file selected, press  $\text{OK}$  to start playback.
- 4 Press  $\blacksquare$  to stop playback.

### Notes:

- From the file list view, if you select the file without pressing  $\text{OK}$ , the content is played on a preview screen. When  $\text{OK}$  is pressed, it is played in full screen mode.
- Depending on the file size, it may take some time to start playback.
- If playback finishes before  $\blacksquare$  is pressed, the screen will return to the list of available file.

### During playback:

- Press **II** to pause.
- To resume normal playback, press  $\blacktriangleright$ .
- To play in fast reverse or fast forward directions, press  $\blacktriangleleft$  or  $\blacktriangleright$  during playback. Each time you press the  $\blacktriangleleft$  or  $\blacktriangleright$ , the playback speed will change.
- To locate a specific file, press  $\blacktriangleleft$  or  $\blacktriangleright$  repeatedly.

### Note:

During playback, you can display a movie list on the screen from the **Play List** in the **Quick Menu**, and then press  $\nabla$  or  $\triangle$  to select a list as desired.

### Selecting subtitle and audio languages

- Press **SUBTITLE** repeatedly to select your preferred subtitle language.
- Press **CV/A** repeatedly to select your preferred audio language.

### Setting the repeat mode

- 1 Press **QUICK** to open the **Quick Menu**.
- 2 Press  $\triangleleft$  or  $\triangleright$  to select **Off**, **All** or **1**.

Mode	Description
<b>Off</b>	The file is played back only once.
<b>All</b>	Files in the same folder are repeatedly played back.
<b>1</b>	The same file is repeatedly played back.

- 3 Press **RETURN**.

### Registering your TV to a DivX® account:

This TV allows you to play back files purchased or rented from DivX® Video-On Demand (VOD) services. When you purchase or rent DivX VOD files on the internet, you will be asked to enter a registration code.

- 1 From the **FUNCTION** menu, press  $\nabla$  or  $\triangle$  to select **Media Player**, and then press  $\text{OK}$ .
- 2 Press  $\nabla$  or  $\triangle$  to select **Setup**, and press  $\text{OK}$ .
- 3 Press  $\nabla$  or  $\triangle$  to select **DivX® VOD Registration**, and then press  $\text{OK}$ .
- 4 The DivX® VOD window will appear and you will see the registration code. For details on registration, please visit the DivX® website at <http://vod.divx.com>.
- 5 Copy the activation file to a memory device and play it on the TV.

### Deactivating your device

- 1 In step 3 above, select **DivX® VOD Deactivation**, and then press  $\text{OK}$ .
- 2 A confirmation screen will appear. Select **Yes**, and then press  $\text{OK}$ .
- 3 The **DivX® VOD** window will appear and you will see the deactivation code. For details on registration, please visit the DivX® website at <http://vod.divx.com>.

**ABOUT DIVX VIDEO:** DivX® is a digital video format created by DivX, Inc. This is an official DivX Certified device that plays DivX video. Visit [www.divx.com](http://www.divx.com) for more information and software tools to convert your files into DivX video.

**ABOUT DIVX VIDEO-ON-DEMAND:** This DivX Certified® device must be registered in order to play purchased DivX Video-on-Demand (VOD) movies.

To obtain your registration code, locate the DivX® VOD section in your device setup menu. Go to [vod.divx.com](http://vod.divx.com) for more information on how to complete your registration.

### Closing the Movie Viewer

**1** Press **EXIT**.

### File Compatibility

**USB device use, see page 31.**

### Playing music files

You can listen to music from a list of available files.

**1** When it is displayed the Multi View, press  $\nabla$ ,  $\triangle$ ,  $\triangleleft$  or  $\triangleright$  to select a file or folder. **P $\nabla$**  or **P $\triangle$**  buttons can be used to page up/down the music list when there are more files than will fit onto one screen.

**2** When you select a folder, press **OK** to move to the next layer. Select **Up Folder** to move back to the previous layer.

**3** With the desired file selected, press **OK** to start playback.

**4** Press **■** to stop playback.

#### Note:

*Depending on the file size, it may take some time for playback to begin.*

### During playback:

- Press **II** to pause.
- To resume normal playback, press **▶**.
- To play in fast reverse or fast forward directions, press **◀◀** or **▶▶** during playback. Each time you press **◀◀** or **▶▶**, the playback speed will change.
- To locate a specific file, press **◀◀** or **▶▶** repeatedly.

#### Note:

*During playback, you can display a music list on the screen from the **Play List** in the **Quick Menu**, and then press  $\nabla$  or  $\triangle$  to select a list as desired.*

### Setting the repeat mode:

**1** Press **QUICK** to open the **Quick Menu**.

**2** Press  $\triangleleft$  or  $\triangleright$  to select **Off**, **All** or **1**.

Mode	Description
<b>Off</b>	Files in the same folder are played back once.
<b>All</b>	Files in the same folder are repeatedly played back.
<b>1</b>	The same file is repeatedly played back.

**3** Press **RETURN**.

### Closing the Music Player:

**1** Press **EXIT**.

### File Compatibility

**USB device use, see page 31.**

**APPENDIX**

**Media Player Supported Formats**

Media Player	Media Format	File Extention	Video/Audio codec	Note
Photo	JPEG BMP	.jpg .jpeg .bmp		Data compatibility: JPEG Exif ver 2.2 Maximum viewable resolution: <JPEG> 15360 × 8640 (Base-line) 1024 × 768 (Progressive) <BMP> 9600 × 6400 Maximum number of files: 1999 / folder
Movie	AVI	.avi	Video) MPEG-2 MPEG-4 part2 H.264(MPEG-4 AVC) DivX 3,4,5,6 (*1) Xvid	Maximum number of files: 1999 / folder Maximum viewable resolution: DivX: 720 × 576 Motion JPEG: 640 × 480 Other: 1920 × 1080  *1) DivX external subtitle file(“.srt”, “.sub”) is supported. Some files may not be played.
			Audio) MPEG-1/2 Layer2 MPEG-1/2 Layer3 Dolby Digital (AC-3) L-PCM ADPCM MPEG-2/4 LC AAC MPEG-4 HE-AAC	
	MPEG-2 PS	.mpg .mpeg	Video) MPEG-1 Video MPEG-2 Video	
			Audio) MPEG-1/2 Layer2 MPEG-1/2 Layer3 Dolby Digital (AC-3) L-PCM	
	MPEG-2 TS	.ts .trp .tp	Video) MPEG-2 Video H.264(MPEG-4 AVC) VC-1(WMV9)	
Audio) MPEG-1/2 Layer2 MPEG-1/2 Layer3 Dolby Digital (AC-3) MPEG-2/4 LC AAC MPEG-4 HE-AAC				
MPEG-2 VOB	.vob	Video) MPEG-1 Video MPEG-2 Video		
		Audio) MPEG-1/2 Layer2 MPEG-1/2 Layer3 Dolby Digital (AC-3) L-PCM		

*Reference section*

Media Player	Media Format	File Extention	Video/Audio codec	Note
Movie	MOV	.mov	Video) MPEG-4 part2 H.264(MPEG-4 AVC)	
			Audio) MPEG-1/2 Layer3 MPEG-2/4 LC AAC MPEG-4 HE-AAC	
	MP4	.mp4 .m4v	Video) MPEG-4 part12 H.264(MPEG-4 AVC)	
			Audio) MPEG-1/2 Layer3 MPEG-2/4 LC AAC MPEG-4 HE-AAC	
	ASF	.asf .wmv	Video) VC-1(WMV9)	
			Audio) WMA7/8/9 Std WMA9 Pro	
	DivX	.divx .div	Video) DivX 3,4,5,6 (*1)	
			Audio) MPEG-1/2 Layer2 MPEG-1/2 Layer3 Dolby Digital (AC-3) L-PCM ADPCM	
	Xvid	.xvid	Video) Xvid	
			Audio) MPEG-1/2 Layer2 MPEG-1/2 Layer3 Dolby Digital (AC-3) L-PCM ADPCM	
MKV	.mkv	Video) MPEG-1 Video MPEG-2 Video MPEG-4 part2 H.264(MPEG-4 AVC)		
		Audio) MPEG-1/2 Layer2 MPEG-1/2 Layer3 Dolby Digital (AC-3) L-PCM MPEG-2/4 LC AAC MPEG-4 HE-AAC		
RealMedia	.rm .rmvb	Video) RelVideo 8,9,10		
		Audio) Dolby Digital (AC-3) MPEG-2/4 LC AAC		

## Reference section

Media Player	Media Format	File Extention	Video/Audio codec	Note
Movie	Flash Video (FLV1)	.flv	Video) Sorenson H.263(FLV1) H.264(MPEG-4 AVC)	
			Audio) MPEG-1/2 Layer3 MPEG-2/4 LC AAC L-PCM ADPCM	
	3GPP	.3gp	Video) MPEG-4 part2 H.264(MPEG-4 AVC)	
			Audio) MPEG-2/4 LC AAC	
	Motion JPEG	.avi .mov	Video) JPEG	
			Audio) L-PCM ADPCM	
Music	MP3	.mp3	MPEG-1/2 Layer-3	Maximum number of files: 1999 / folder
	MP4	.mp4 .m4a	MPEG-2/4 LC AAC	
			WMA	
	WAV	.wav	L-PCM ADPCM MPEG-1/2 Layer-3 WMA7/8/9/ Std WMA9 Pro	

## Troubleshooting

Before calling a service technician, please check the following table for a possible cause of the symptom and some solutions.

### Symptom and solution



#### TV will not turn on

- Make sure the power cord is plugged in, and then press .
- The remote control batteries may be dead. Replace the batteries.

#### No picture, no sound

- Check the aerial connections.

#### No sound, picture OK

- The sound may be muted. Press  +, - or .
- The station may have broadcast difficulties. Try another channel.

#### Poor sound, picture OK

- The station may have broadcast difficulties. Try another channel.

#### Poor picture, sound OK

- Check the aerial connections.
- The station may have broadcast difficulties. Try another channel.
- Adjust the **PICTURE** menu.

#### Poor reception of broadcast channels

- Check the aerial connections.
- The station may have broadcast difficulties. Try another channel.
- Make sure the **Colour System** is properly set.

#### Teletext problems

- Check the aerial connections. Good performance of text depends on a good strong broadcast signal.

### Some pixels of the screen do not light up

- The LCD display panel is manufactured using an extremely high level of precision technology, however, sometimes some pixels of the screen may be missing picture elements or have luminous spots. This is not a sign of a malfunction.

### The picture brightness varies when you display switch the TV on.

- If you switch the TV on at 0°C and under, wait until the warms up.

### Multiple images

- The station may have broadcast difficulties. Try another channel.
- Aerial reception may be poor. Use a high directional outdoor aerial.
- Check if the direction of the aerial has changed.

### Poor colour or no colour

- The station may have broadcast difficulties. Try another channel.
- Adjust the **Tint** and/or **Colour** in the **PICTURE** menu.

### The remote control does not operate

- Remove all obstructions between the remote control and the remote control sensor on the TV.
- The remote control batteries may be dead. Replace the batteries.

## Broadcast system

### Broadcast transmission systems of each country or region

#### Asia M.E.

Country or region	Colour	Sound
Bahrain, Kuwait, Israel, Oman, Qatar, United Arab Emirates, Yemen, etc. Indonesia, Malaysia, Singapore, Thailand, etc.	PAL	B/G
China, Vietnam	PAL	D/K
China Hong Kong	PAL	I
Iraq, Islamic Republic of Iran, Lebanon, Saudi Arabia, etc.	SECAM	B/G
Russian Federation, etc.	SECAM	D/K
Myanmar, Republic of the Philippines, etc.	NTSC	M

#### Oceania

Country or region	Colour	Sound
Australia, New Zealand, etc.	PAL	B/G

#### Africa

Country or region	Colour	Sound
Republic of South Africa, etc.	PAL	I

#### South America

Country or region	Colour	Sound
Brazil	PAL	M
Chile, Colombia, etc.	NTSC	M

#### Note:

*PAL, SECAM and NTSC 3.58 (MHz) are different colour signal broadcast transmission systems applicable to different countries or region. NTSC 4.43 (MHz) is used in special VCRs to playback NTSC recorded video tapes through PAL TV equipment.*

## Specifications

### LCD colour TV

#### Model

24PS10E, 24PS10T, 24PS10V, 24PS10ZE,  
32PS10E, 32PS10T, 32PS10V, 32PS10ZE,  
40PS10E, 40PS10T, 40PS10V, 40PS10ZE

#### Power source

110V-240V AC, 50/60Hz

#### Power consumption

24" : 40 W, 0.8 W (standby)  
32" : 63 W, 0.8 W (standby)  
40" : 91 W, 0.5 W (standby)

#### Dimensions

24" : 578 mm (W) 455 mm (H) 195 mm (D)  
32" : 768 mm (W) 564 mm (H) 217 mm (D)  
40" : 961 mm (W) 675 mm (H) 240 mm (D)

#### Mass (Weight)

24" : 5.5 kg  
32" : 9.0 kg  
40" : 12.5 kg

#### TV system (Aerial input)

Channel coverage:

PAL	B/G	(CCIR)	VHF	2 - 12
			UHF	21 - 69
			CATV	X - Z+2, S1 - S41
PAL	I	(UK)	VHF	-
			UHF	21 - 69
			CATV	-
PAL	D/K	(CHINA)	VHF	1 - 12
			UHF	13 - 57
			CATV	Z1 - Z38
SECAM	B/G	(CCIR)	VHF	2 - 12
			UHF	21 - 69
			CATV	X - Z+2, S1 - S41
SECAM	D/K	(OIRT)	VHF	1 - 12
			UHF	21 - 69
			CATV	X1 - X19
NTSC	M	(US)	VHF	2 - 13
			UHF	14 - 69
			CATV	A6 - A1, A - W, AA - ZZ, AAA, BBB
NTSC	M	(JAPAN)	VHF	1 - 12
			UHF	13 - 62
			CATV	M1 - M10, S1 - S41

Special RF signal:

NTSC 4.43 colour system  
5.5/6.0/6.5 MHz sound system  
PAL 60 Hz colour system  
5.5/6.0/6.5 MHz sound system

#### COMPONENT VIDEO INPUT terminals (the signal format)

480i, 480p, 576i, 576p, 720p (50/60 Hz),  
1080i (50/60 Hz)

(These signal formats are converted to match the number of pixels of the LCD panel.)

#### Colour System

PAL, SECAM, NTSC 3.58/4.43

#### Aspect ratio

16 : 9

#### Visible size (diagonal)

24" : 59.8 cm  
32" : 80.0 cm  
40" : 101.6 cm

#### Number of pixels

24"/40" : 1920 (H) dots × 1080 (V) dots  
32" : 1366 (H) dots × 768 (V) dots

#### Audio power

10 W + 10 W

#### Speakers

24" : Main 42 × 70 mm 2pcs.  
32"/40" : Main 42 × 160 mm 2pcs.

#### Input/Output terminals

⊖ (1)	Input	
	Phono jacks	A/V
⊖ (2)	Input	
	COMPONENT / VIDEO INPUT	Standard video or Component video
⊖ RGB/PC	Input	
	Mini D-sub 15 pin Analogue RGB	
⊖ PC/HDMI 1 (AUDIO)	Input	
	3.5 mm (Diameter) stereo	
⊖ HDMI1-2	Input (type A)	
	19 pin	A/V Digital
USB port	HDMI (Lip Sync)	
	Media Player Interface version: USB 2.0	
	USB class: Mass Storage	
	File system: FAT16 and FAT32	

#### Operating condition

Temperature 0°C - 35°C  
Humidity 20% - 80% (No moisture condensation)

#### Supplied accessories

Owner's manual (1), Power cord (1), Remote control (1), Batteries (2), Screw (1) (see page 2) (not supplied on 24" models), Pedestal stand (1)

- Design and specifications are subject to change without notice.
- Never service or remodel the TV by yourself. It may expose you to a fire hazard or dangerous voltages.

### **Trademark Information**

- HDMI, the HDMI logo, and High-Definition Multimedia Interface are trademarks or registered trademarks of HDMI Licensing LLC in the United States and other countries.
- Manufactured under license from Dolby Laboratories. Dolby and the double-D symbol are trademarks of Dolby Laboratories.
- DivX®, DivX Certified® and associated logos are registered trademark of DivX, Inc., and it is used under license.  
Covered by one or more of the following U.S. Patents: 7,295,673; 7,460,668; 7,515,710; 7,519,274
- THIS PRODUCT IS LICENSED UNDER THE AVC PATENT PORTFOLIO LICENSE FOR THE PERSONAL AND NONCOMMERCIAL USE OF A CONSUMER TO (i) ENCODE VIDEO IN COMPLIANCE WITH THE AVC STANDARD (AVC VIDEO) AND/OR (ii) DECODE AVC VIDEO THAT WAS ENCODED BY A CONSUMER ENGAGED IN A PERSONAL AND NONCOMMERCIAL ACTIVITY AND/OR WAS OBTAINED FROM A VIDEO PROVIDER LICENSED TO PROVIDE AVC VIDEO. NO LICENSE IS GRANTED OR SHALL BE IMPLIED FOR ANY OTHER USE. ADDITIONAL INFORMATION MAY BE OBTAINED FROM MPEG LA, L.L.C. SEE [HTTP://WWW.MPEGLA.COM](http://WWW.MPEGLA.COM)
- MPEG Layer-3 audio coding technology licensed from Fraunhofer LLS and Thomson.

- THIS PRODUCT IS LICENSED UNDER THE VC-1 PATENT PORTFOLIO LICENSE FOR THE PERSONAL AND NON COMMERCIAL USE OF A CONSUMER TO (i) ENCODE VIDEO IN COMPLIANCE WITH THE VC-1 STANDARD (VC-1 VIDEO) AND/OR (ii) DECODE VC-1 VIDEO THAT WAS ENCODED BY A CONSUMER ENGAGED IN A PERSONAL AND NON COMMERCIAL ACTIVITY AND/OR WAS OBTAINED FROM A VIDEO PROVIDER LICENSED TO PROVIDE VC-1 VIDEO. NO LICENSE IS GRANTED OR SHALL BE IMPLIED FOR ANY OTHER USE. ADDITIONAL INFORMATION MAY BE OBTAINED FROM MPEG LA, L. L. C. SEE [HTTP://WWW.MPEGLA.COM](http://WWW.MPEGLA.COM)
- THIS PRODUCT IS LICENSED UNDER THE MPEG-4 VISUAL PATENT PORTFOLIO LICENSE FOR THE PERSONAL AND NON COMMERCIAL USE OF A CONSUMER FOR (i) ENCODING VIDEO IN COMPLIANCE WITH THE MPEG-4 VISUAL STANDARD (MPEG-4 VIDEO) AND/OR (ii) DECODING MPEG-4 VIDEO THAT WAS ENCODED BY A CONSUMER ENGAGED IN A PERSONAL AND NON COMMERCIAL ACTIVITY AND/OR WAS OBTAINED FROM A VIDEO PROVIDER LICENSED BY MPEG LA TO PROVIDE MPEG-4 VIDEO. NO LICENSE IS GRANTED OR SHALL BE IMPLIED FOR ANY OTHER USE. ADDITIONAL INFORMATION INCLUDING THAT RELATING TO PROMOTIONAL, INTERNAL AND COMMERCIAL USES AND LICENSING MAY BE OBTAINED FROM MPEG LA, L. L. C. SEE [HTTP://WWW.MPEGLA.COM](http://WWW.MPEGLA.COM)