



TOSHIBA



Blu-ray Disc™ Player



BDX3200KA

Owner's Manual



Contents

1 Important	3-6
Safety and important notice.....	3-6
2 Your Product	7-9
Regions codes	7
Product overview	8
Remote Control.....	9
3 Connections	10-11
Connecting to a TV	10
Optional Connection.....	11
Connect USB device	11
Connect power	11
4 Preparation	12
Prepare the remote control	12
Setting up the player.....	12
5 Playback	13-15
Playback Functions.....	13-15
6 Customizing	16-22
General Setting.....	16-19
Display Setting.....	20-21
Audio Setting	21-22
System Information.....	22
7 Specification	23
8 Troubleshooting	24-25
9 Glossary	26-27
10 License Information	28-46

1 Important

Safety and important notice

SAFETY PRECAUTIONS

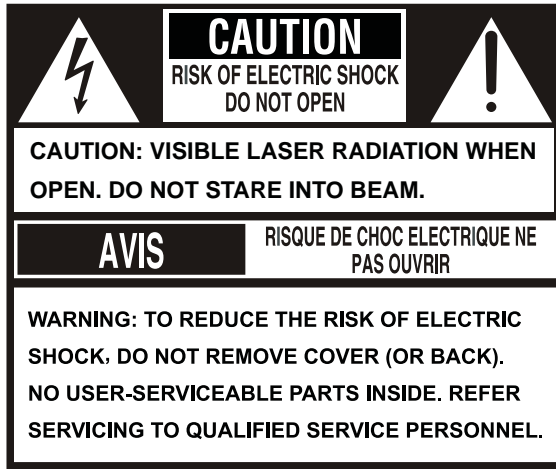

This symbol is intended to alert the user of the presence of uninsulated 'dangerous voltage' within the product's enclosure that may be of sufficient magnitude to constitute a risk of electric shock to people.



The exclamation point within an equilateral triangle is intended to alert the user to the presence of important operating and maintenance (servicing) instructions in the literature accompanying the appliance.



The symbol for CLASS II (Double Insulation)

WARNING:

TO REDUCE THE RISK OF FIRE OR ELECTRIC SHOCK, DO NOT EXPOSE THIS APPLIANCE TO RAIN OR MOISTURE. DANGEROUS HIGH VOLTAGES ARE PRESENT INSIDE THE ENCLOSURE. DO NOT OPEN THE CABINET. REFER SERVICING TO QUALIFIED PERSONNEL ONLY.

CAUTION:

PLEASE READ AND OBSERVE ALL WARNINGS AND INSTRUCTIONS GIVEN IN THIS OWNER'S MANUAL AND THOSE MARKED ON THE UNIT. RETAIN THIS BOOKLET FOR FUTURE REFERENCE.

CAUTION:

USE OF ANY CONTROLS, ADJUSTMENTS, OR PROCEDURES OTHER THAN THOSE SPECIFIED HEREIN MAY RESULT IN HAZARDOUS RADIATION EXPOSURE.

Changes or modifications made to this equipment, not expressly approved by Toshiba, or parties authorized by Toshiba, could void the user's authority to operate the equipment.

IMPORTANT SAFETY INSTRUCTIONS

This unit has been designed and manufactured to

assure personal safety. Improper use can result in electric shock or fire hazard. The safeguards incorporated in this unit will protect you if you observe the following procedures for installation, use and servicing. This unit is fully transistorized and does not contain any parts that can be repaired by the user. **DO NOT REMOVE THE CABINET COVER, OR YOU MAY BE EXPOSED TO DANGEROUS VOLTAGE. REFER SERVICING TO QUALIFIED SERVICE PERSONNEL ONLY.**

1. Read these instructions.
2. Keep these instructions.
3. Read all warnings.
4. Follow all instructions.
5. Do not use this appliance near water.
6. Clean only with dry cloth.
7. Do not block any ventilation openings. Install in accordance with the manufacturer's instructions.
8. Do not install near any heat sources such as radiators, heat registers, stoves, or other apparatus (including amplifiers) that produce heat.
9. Protect the power cord from being walked on or pinched particularly at plugs, convenience receptacles, and the point where they exit from the apparatus.
10. Only use attachments/accessories specified by the manufacturer.
11. Use only with the cart, stand, tripod, bracket, or table specified by the manufacturer, or sold with the apparatus. When a cart is used, use caution when moving the cart/apparatus combination to avoid injury from tip-over. 
12. Unplug this apparatus during lightning storms or when unused for long periods of time.
13. Refer all servicing to qualified service personnel. Servicing is required when the apparatus has been damaged in any way, such as power-supply cord or plug is damaged, liquid has been spilled or objects have fallen into the apparatus, the apparatus has been exposed to rain or moisture, does not operate normally, or has been dropped.
14. Do not overload wall outlets; extension cords, or integral convenience receptacles as this can result in a risk of fire or electric shock.
15. Apparatus shall not be exposed to dripping or splashing and no objects filled with liquids, such as vases, shall be placed on the apparatus.
16. Keep your fingers well clear of the disc tray as it is closing. Neglecting to do so may cause serious personal injury.
17. Do not place a heavy object on or step on the apparatus. The object may fall, causing serious personal injury and serious damage to the apparatus.
18. Do not use a cracked, deformed or repaired disc. These discs are easily broken and may cause serious personal injury and apparatus malfunction.
19. If the apparatus should smoke or smell, immediately disconnect the power cord from the wall outlet. Wait until the smoke or smell stops, then ask your dealer for a check and repair. Neglecting to do so may cause fire.
20. While it is thundering, do not touch the connecting cables or the apparatus.

CAUTION:

This Player employs a Laser System.

To ensure proper use of this product, please read this owner's manual carefully and retain for future reference. Should the unit require maintenance, contact an authorized service location.

Use of controls or adjustments or performance of procedures other than those specified herein may result in hazardous radiation exposure.

To prevent direct exposure to laser beam, do not try to open the enclosure.

Visible and invisible laser radiation when open and interlocks defeated.

DO NOT STARE INTO BEAM.

CAUTION: These servicing instructions are for use by qualified service personnel only. To reduce the risk of electric shock do not perform any servicing other than that contained in the operating instructions unless you are qualified to do so.

Be aware that this equipment is still powered when in standby mode. To disconnect this equipment completely from the mains power, pull out the power plug from the wall outlet.

Where the MAINS plug or an appliance coupler is used as the disconnect device, the disconnect device shall remain readily operable.

Copyright notice

This product incorporates copyright protection technology that is protected by U.S. patents and other intellectual property rights. Use of this copyright protection technology must be authorized by Rovi Corporation, and is intended for home and other limited viewing uses only unless otherwise authorized by Rovi Corporation. Reverse engineering or disassembly is prohibited.



Be responsible
Respect copyrights

Disclaimers

I. HEALTH/SAFETY-RELATED IMPORTANT SAFETY INFORMATION CONCERNING 3D VIEWING

- If you or any viewer experiences the following symptoms or any other discomfort from viewing 3D video images, stop viewing and contact your health care provider:

Convulsions	Eye or muscle twitching
Loss of awareness	Altered vision
Involuntary movements	Disorientation
Eye Strain	Nausea/Vomiting
Dizziness	Headaches
Fatigue	

- Some viewers may experience a seizure or blackout when exposed to certain flashing images or lights contained in certain 3D television pictures or video games. Anyone who has had a seizure, loss of awareness, or other symptom linked to an epileptic condition, or has a family history of epilepsy, should contact a health care provider before using the 3D function.

- If you feel eye fatigue or other discomfort from viewing 3D video images, stop viewing and take a rest until the condition is eliminated.

- Due to the possible impact on vision development, viewers of 3D video images should be age 6 or above. Children and teenagers may be more susceptible to health issues associated with viewing in 3D and should be closely supervised to avoid prolonged viewing without rest.

- Avoid use of the 3D function when under the influence of alcohol.

- Watching the screen while sitting too close for an extended period of time may cause eye strain. Consult your display manual to determine the ideal viewing distance.

- Viewing in 3D may cause dizziness and/or disorientation for some viewers.

Therefore, to avoid injury do not place your player or display near open stairwells, balconies, or wires, and do not sit near objects that could be broken if accidentally hit.

- CAREFULLY READ INSTRUCTIONS PROVIDED WITH YOUR DISPLAY AND/OR 3D GLASSES BEFORE 3D VIEWING.

II. PERFORMANCE RELATED

- This product is designed to playback Blu-ray™ discs that comply with the 3D

specifications of Blu-ray Disc Association. It is not compatible with other 3D specifications.

- 3D capable display, 3D eyewear and High Speed HDMI cable (all sold separately) required for playback and viewing 3D content.
- If you route your signal through an AV receiver or other video distribution device they must be 3D capable to support 3D viewing. Viewing HD content and up-converting DVD content may require an HDCP capable input on your display device.
- While up-converting DVD video content may result in a picture that appears to be near HD quality, results may vary depending on content, display and settings.
- 1080p capable display required for viewing content in 1080p.
- 1080p/24 fps encoded content and an HD display capable of accepting a 1080p/24Hz signal required for viewing 1080p/24 fps content.
- Performance of interactive and/or network features may vary due to disc design or content, and may also require an always-on broadband internet connection. Firmware update may be required for some interactive and/or network features. Some features may require additional bandwidth.
- BD-Live™ may require an SD or SDHC card or USB memory with available storage capacity of at least 1GB (sold separately).
- For Dolby® TrueHD and DTS-HD Master Audio | Essential™ playback, content encoded in Dolby® TrueHD and DTS-HD Master Audio | Essential™ format required. Supported file types: JPEG, MP3, DivX and AVCHD. Some recordable media, cards or files may not be supported. Deep Color feature as specified in HDMI specification requires compatible Deep Color capable HD display and/or device. Use of HDMI-CEC requires an HDMI-CEC

compatible display device. Depending on the specifications of your display device, some or all HDMI-CEC functions may not work even if your display device is HDMI-CEC compatible.

- Products do not play HD DVD discs.
- Some features subject to delayed availability.
- Because the Blu-ray™ format and 3D specifications use new technologies, certain disc, content, connection and other compatibility and/or performance issues are possible. If you experience such issues, please refer to www.home-entertainment.toshiba.co.uk (for UK models) or <http://eu.consumer.toshiba.eu/en> (for Europe continental models) to get information on the availability of firmware updates that may resolve your problem, or contact Toshiba Customer Solutions.
- While every effort has been made at the time of publication to ensure the accuracy of the information provided herein, product specifications, configurations, system/component/options availability are all subject to change without notice.

Notice for Trademark



HIGH-DEFINITION MULTIMEDIA INTERFACE

HDMI, the HDMI logo and High-Definition Multimedia Interface are trademarks or registered trademarks of HDMI Licensing LLC in the United States and other countries.



Manufactured under license from Dolby Laboratories. Dolby and the double-D symbol are trademarks of Dolby Laboratories.



Manufactured under license under U.S. Patent #'s: 5,451,942; 5,956,674; 5,974,380; 5,978,762; 6,226,616; 6,487,535; 7,392,195; 7,272,567; 7,333,929; 7,212,872 & other U.S. and worldwide patents issued & pending. DTS and the Symbol are registered trademarks, & DTS-HD, DTS-HD Master Audio | Essential and the DTS logos are trademarks of DTS, Inc. Product includes software. © DTS, Inc. All Rights Reserved.



BONUS VIEW™

Blu-ray Disc™, Blu-ray™, BD-Live™, BONUSVIEW™, and the logos are trademarks of the Blu-ray Disc Association.



'AVCHD' and the 'AVCHD' logo are trademarks of Panasonic Corporation and Sony Corporation.



'DVD Video' is a trademark of DVD Format/Logo Licensing Corporation.



"Blu-ray 3D™" and "Blu-ray 3D™" logo are trademarks of Blu-ray Disc Association.



Oracle and Java are registered trademarks of Oracle and/or its affiliates. Other names may be trademarks of their respective owners.



ABOUT DIVX VIDEO:

DivX® is a digital video format created by DivX, Inc. This is an official DivX Certified® device that plays DivX video. Visit divx.com for more information and software tools to convert your files into DivX video.

ABOUT DIVX VIDEO-ON-DEMAND:

This DivX Certified® device must be registered in order to play purchased DivX Video-on-Demand (VOD) movies. To obtain your registration code, locate the DivX VOD section in your device setup menu. Go to vod.divx.com for more information on how to complete your registration.

DivX®, DivX Certified® and associated logos are trademarks of DivX, Inc. and are used under license.













For HD Test Kit 1080p v1.1 and later: DivX Certified® to play DivX® video up to HD 1080p, including premium content.







2 Your Product

Regions Codes

Both the Blu-ray Disc™ player and the discs are coded by region. These regional codes must match in order to play the disc. If the codes do not match, the disc will not play.

The Region Number for this Blu-ray Disc™ player is described on the rear panel of the Blu-ray Disc™ player.

Region	DVD discs that can be played
U.S.A. and Canada regions	 
U.K., Europe regions and Japan	 
Asia Pacific, Taiwan, Korea	 
Australia, New Zealand, Latin America	 
Russia and India regions	 
China, Calcos Islands, Walls and Futuna Islands	 

Region	Blu-ray™ discs that can be played
North America, Central America, South America, Korea, Japan, Taiwan, Hong Kong and South East Asia.	 
Europe, Greenland, French territories, Middle East, Africa, Australia and New Zealand.	 
India, China, Russia, Central and South Asia.	 

Feature highlights

High-Definition entertainment
Watch high-definition content disc with HDTV (High Definition Television). Connect it through a high speed HDMI cable (1.4 or category 2). You can enjoy excellent picture quality up to 1080p resolution with the frame rate of 24 frames per second with progressive scan output.

BD-Live™

Connect this player to the movie studios website via the LAN jack to access a variety of up-to-date content (e.g. refreshed previews and exclusive special features).

Blu-ray Disc™ Java

Blu-ray Disc™ Java(BD-J) Application
The BD-ROM format supports Java for interactive functions. "BD-J" offers content providers almost unlimited functionality when creating interactive BD-ROM titles.

Product overview

Main Unit

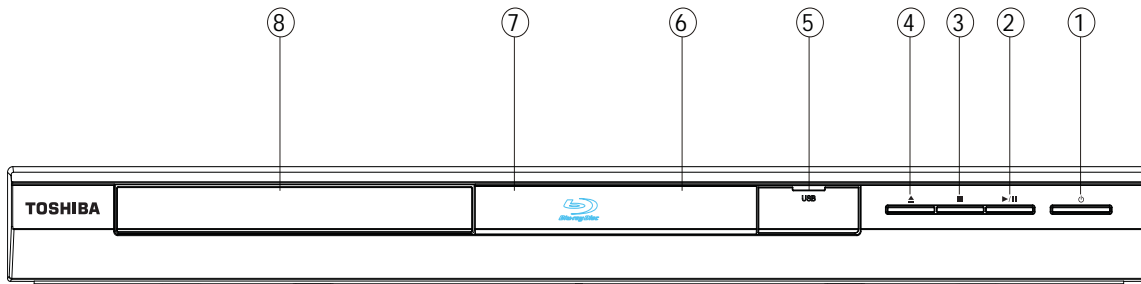

NO	Control	Function
①	⏻	Turns the power on or restores the unit to the standby mode.
②	▶/⏸	Playback/Pause.
③	■	Stop play.
④	⏏	Open or close the disc compartment.
⑤	USB jack	Connect a USB flash drive.
⑥	Display panel	Show information about the current status of this unit.
⑦	IR Sensor	Point the remote control at the IR sensor.
⑧	Disc compartment	Loads a disc into the disc drive.

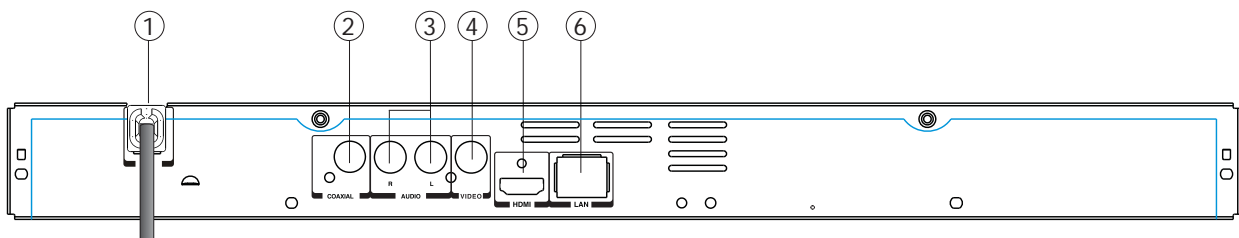

NO	Control	Function
①	AC power cord	Connects to a standard AC outlet.
②	COAXIAL jack	Output digital audio signals when connecting the coaxial digital cable.
③	ANALOG AUDIO OUTPUT jacks	Outputs audio signals to a connected TV or AV amplifier.
④	VIDEO OUTPUT jack	Output video signals to a connected TV.
⑤	HDMI OUTPUT jack	Outputs video/audio signals to a connected TV, monitor or AV amplifier. Connect to a TV, monitor or AV amplifier equipped with HDMI input.
⑥	LAN jack	Use this to connect to a network with an always-on broadband connection. It is reserved for future usage of BD-Live™.

Remote Control

REMOTE SIGNAL EMITTER

- Point remote control to the sensor on the front panel

ON / STANDBY

- To switch the Blu-ray Disc™ player to ON or standby mode

SETUP

- Enters or exits the system setup menu
 - MC(Media Center)
 - To open/close Media Center

2nd AUDIO

- Switch the secondary audio of secondary video(PIP) to on or off

SEARCH

- To search a title, chapter, track or playing time

HDMI

- To change resolution of HDMI video output to fit TV. Such as 1080p, 1080i... etc.

◀◀/▶▶PREV & NEXT

- Skip to previous/next chapter/ title/track

■ STOP

- Stop playback

◀◀/▶▶

- Instant replay/instant search

◀◀/▶▶ F.R & F.F

- Fast reverse/ fast forward

▶|| PLAY/PAUSE

- Start/Pause playback

PROGRAM

- To access program list.

BOOKMARK

- To bookmark at any point during playback

ZOOM

- To zoom out/in

DIGEST

- To access JPEG thumbnail view during playback

Number Buttons

- Select numbered items in a menu
- Press to enter track/ chapter/ title numbers/password directly

◀

- Slow reverse

▶

- Slow forward

◀◀

- To reverse the picture frame by frame

▶▶

- To advance the picture frame by frame

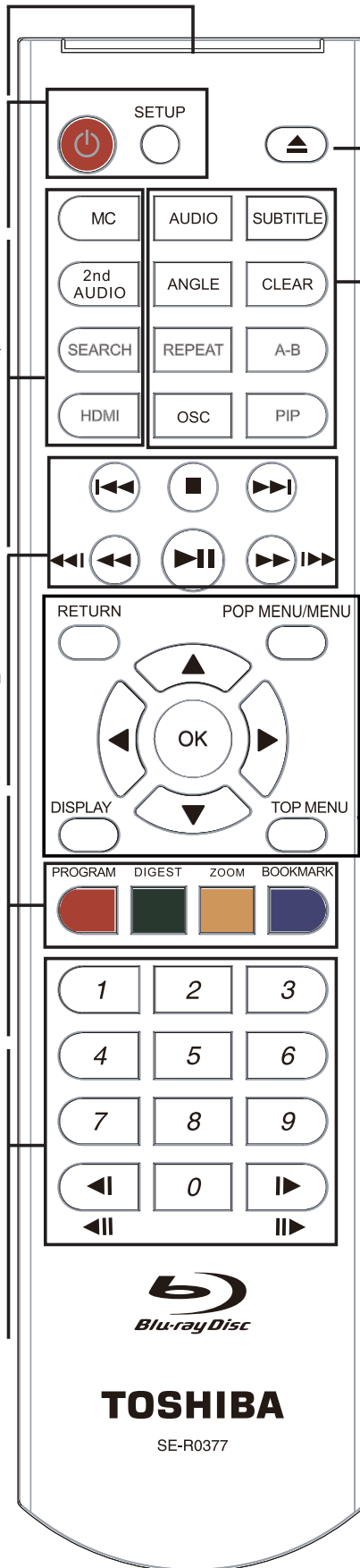

▲ OPEN/CLOSE

- Open/ Close the disc tray

AUDIO

- To select the sound stream; press repeatedly to select different audio streams available in your disc

SUBTITLE

- To display subtitle; press repeatedly to select different subtitles available in your disc

ANGLE

- Switch the camera angle during playback

CLEAR

- To clear an entry or the bookmark and program you set

REPEAT

- Selects various repeat mode.

REPEAT A-B

- To repeat from A to B

PIP (Picture in Picture)

- Switch on or off the secondary video

OSC

- To access On Screen Control menu

RETURN

- Return to previous menu

POP MENU/MENU

- To display a menu included on many Blu-ray™/DVD video discs

TOP MENU

- To display the disc title during playback

DISPLAY

- To display a window to locate a title, chapter or track

OK

- Acknowledge/ Confirm menu selection

◀▶▲▼

- Navigation/ Cursor buttons for moving to the left / right / up / down

- Press ◀/▶ during JPEG playback to rotate the current photo track, but the JPEG playback will be paused

3 Connections

Make the following connections to use this product.

Connecting to a TV

Connect the product to TV to view disc play. Select the best video connection that TV can support:

Option 1: Connect to the composite video jack(VIDEO)

Option 2: Connect to the HDMI Jack

Option 1: Connect to the composite video jack (VIDEO)

You can connect this product to a TV through the composite video cable which provides standard picture quality.

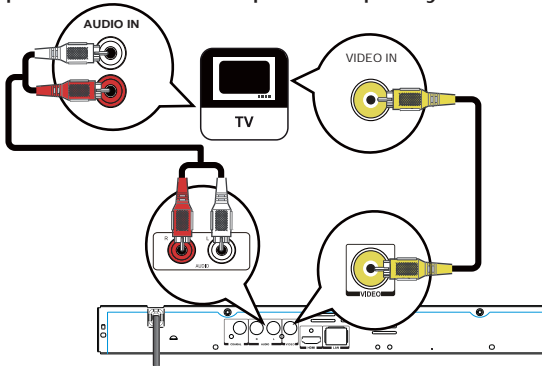

1. Connect a composite cable from the VIDEO OUT jack and analogue AUDIO OUT jacks on this product to the video input jack(yellow) and audio input jacks(white/red) on the TV.

Note:

-Connect this unit directly to the TV. If the composite Audio / video cables are connected to a VCR, pictures may be distorted due to the copy right protection system.

Option 2: Connect to the HDMI Jack

This type of connection provides better picture quality.

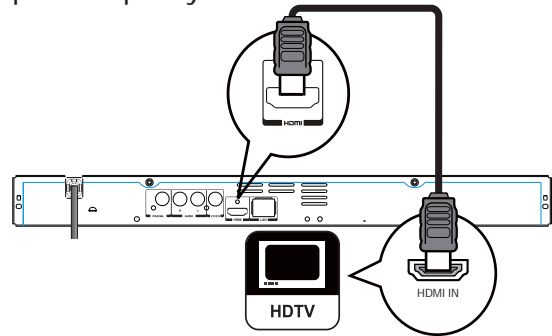

1. Connect a HDMI cable from the HDMI output jack on this product to the HDMI input jack on the TV.

Notes:

- If the TV has a DVI connector only, connect via an HDMI/DVI adapter. Connect an audio cable for sound output.
- You can optimize the video output by pressing the HDMI button repeatedly to select the best resolution which the TV can support.
- When the player is connected to both VIDEO OUTPUT jack and HDMI OUTPUT jack, resolution is set to 720p/1080i/1080p, there will be no video output through VIDEO OUTPUT jack.

Optional Connection

Option 1: Connect to the digital amplifier/receiver

Option 2: Connect to an analogue stereo system

Option 3: Connect to network

Option 1: Connect to the digital amplifier/receiver

Route the sound from this player to other device to enhance audio output.

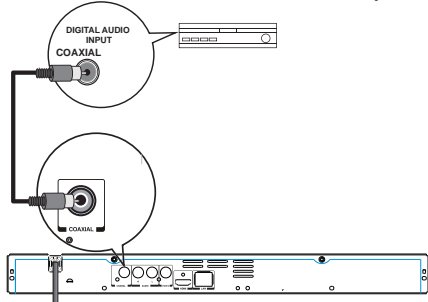

1. Connect a coaxial cable from the COAXIAL jack on this product to the COAXIAL jack on the device.

Option 2: Connect to an analogue stereo system

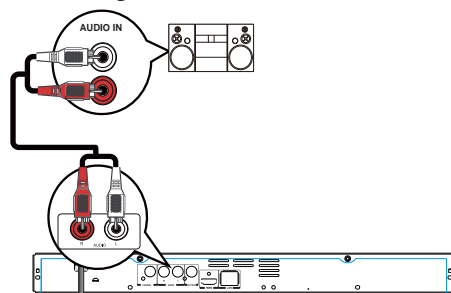

1. Connect the audio cable from the analogue AUDIO OUT jacks on this product to the audio input jacks on the system.

Option 3: Connect to network

Connect this product to the network to enjoy BD-Live™ bonus content.

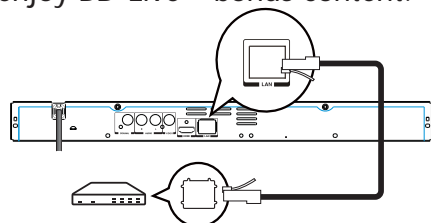

1. Connect the network cable from the LAN jack on the product to the LAN jack on the network system.

Connect USB device

A USB device provides an additional memory to software upgrade and enjoy BD-Live™ bonus content.

You can also enjoy playing back MP3/JPEG/MPEG4/DivX® files stored in the USB flash device.

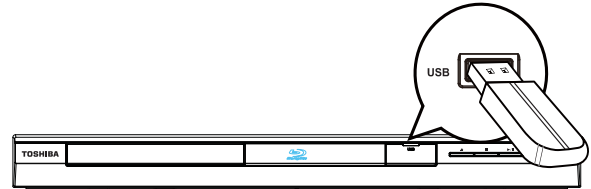

1. Opens the USB cover.
2. Connect the USB Flash device to the USB jack on this product.

Notes:

- Connect only a USB Flash device to the USB jack on this product.

- To enjoy BD-Live™ bonus content, as your local storage, use a **1 GB or larger USB memory**.

- TOSHIBA does not guarantee 100% compatibility with all USB Flash devices.

Connect Power

1. Connect the AC power cable to:
 - the wall socket.
 - The product is ready to be set up for use.

Notes:

- Before connecting the AC power cord, ensure you have completed all other connections.

- Risk of product damage! Ensure that the power supply voltage corresponds to the voltage printed on the back of the unit.

- The type plate is located on the back of the unit.

4 Preparation

Always follow the instructions in this chapter in sequence.

Note:

- Use of controls or adjustments or performance of procedures other than herein may result in hazardous radiation exposure or other unsafe operation.

Prepare the remote control

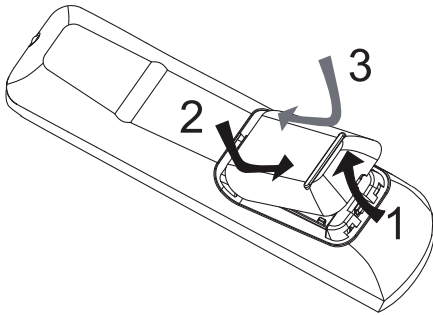

1. Open the battery compartment.
2. Insert two R03 batteries with correct polarity (+/-) as indicated.
3. Close the battery compartment.

Notes:

- If you are not going to use the remote control for a long time, remove the batteries.
- Do not use old and new or different types of batteries in combination.
- Risk of explosion! Keep batteries away from heat, sunshine or fire. Never discard batteries in fire.

• The maximum operable ranges from the unit are as follows.

- Line of sight: approx. 9 m
- Either side of the centre: approx. 7 m within 30°
- Above: approx. 7 m within 30°
- Below: approx. 7 m within 30°

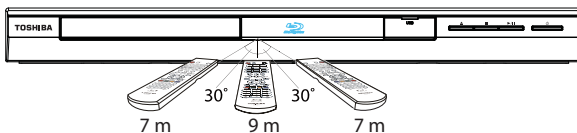

Setting up the player

Find the correct viewing input

1. Press \odot to turn on this product.
2. Turn on the TV and switch to the correct video-in input (refer to the TV user manual on how to select the correct input).

Initial Setting

When you turn on this unit for the first time, you need to follow these steps.

1. A welcome page will be displayed when this product is powered on.
2. Press OK to enter language setting.
3. Select your desired language, resolution and aspect ratio using $\blacktriangle/\blacktriangledown$, then press OK.
4. Press SETUP to exit the Setup menu.

Use the SETUP menu

1. Press SETUP to display the Setup menu when the Blu-ray Disc™ Player is playing or no disc. And press SETUP to exit the Setup menu.

Tip:

- When playing high-definition sources, you must press STOP \blacksquare button to enter SETUP interface.

Select menu display language

1. Press SETUP, [General Setting] menu is displayed.
2. Select [Language], then press \blacktriangleright .
3. Select [OSD], then press \blacktriangleright .
 - The language options may vary for different regions.
4. Press $\blacktriangle/\blacktriangledown$ to select a language, then press OK.





Note:

- If this disc player is connected to a HDMI CEC compliant TV, skip this setting. It switches automatically to the same OSD menu language as per your TV setting.



5 Playback

Playback Functions



Basic Playback

1. Press  button on the front panel or the remote control, your player will turn on. The unit will take around 30 seconds to warm up.
2. Turn on the TV, and then select the input setting on the TV that matches the connection method you used to connect your player.
3. Press OPEN/CLOSE  to slide out the disc tray.
4. Place a disc on the disc tray with the label facing up and then press OPEN/CLOSE  to slide back and close the disc tray. The disc loading time depends on the types of disc you are loading, and loading a Blu-ray Disc™ will take longer time.
5. If the disc does not start playing automatically, please press  to start playback.
6. If a Blu-ray Disc™ or DVD menu displays, use cursor buttons to select PLAY. Then, press OK to confirm.
7. To eject the disc, press OPEN/CLOSE .



Pause playback

1. Press  to pause playback. The sound will be muted.
2. Press  to resume the playback.

Stop playback

1. Press STOP  button once to go to resume mode, the TV screen will show the resume logo.
2. Press STOP  twice to stop the playback completely.
3. Press  to resume playback from the point where playback is stopped or from the beginning of the disc after the playback is completely stopped.
Not all Blu-ray™ discs support the resume feature.



Fast Forward and Fast Reverse

1. Press F.F  to fast forward through the disc. The fast forward speed changes based on how many times you pressed the button. The speed will increase through the following sequence:
2X, 4X, 8X, 16X, 32X
2. Press  to resume playback.
3. Press F.R  to fast reverse through the disc. The fast reverse speed changes based on how many times you pressed the button. The speed will increase through the



following sequence:
2X, 4X, 8X, 16X, 32X

4. Press  to resume playback.

Instant Search and Instant Replay



1. During playback, press and hold  button, you can search 30 seconds forward.
2. During playback, press and hold  button, you can instant replay the content from 10 seconds before.

Previous and Next



During playback, press PREV  button, and you can skip back to the previous chapter or track. Each press of this button will allow you to skip a chapter or track till the beginning of the disc.
Press of NEXT  button during playback will allow you to skip the playback to next chapter or track.

Slow Forward and Slow Reverse

Slow Reverse

1. Press  during normal playback. The slow reverse speed is 1/16 in default.
2. To change slow reverse speed, press  repeatedly, and the slow reverse speed will be changed in the following sequence: 1/16, 1/8, 1/4, 1/2, normal.
3. To exit slow reverse mode and return to normal playback, press .



Slow Forward

1. Press  during normal playback. The slow forward speed is 1/16 in default.
2. To change slow forward speed, press  repeatedly, and the slow forward speed will be changed in the following sequence: 1/16, 1/8, 1/4, 1/2, normal.
3. To exit slow forward mode and return to normal playback, press .



Step Forward/Step Backward

Use this feature to help you to enjoy the video frame by frame.

Step Forward

1. Press  during normal playback, then playback will change to pause state.
2. Press  repeatedly to advance the picture frame by frame.
3. Press  to resume normal playback.

Step Backward

1. Press  during normal playback, then playback will change to pause state.
2. Press  repeatedly to reverse the picture frame by frame.
3. Press  to resume normal playback.

HDMI

When there is file or disc being played, it is not allowed to switch resolution through the HDMI button of the Remote Control.

Advanced Playback

DISPLAY

Press this button and the screen will display some information about disc, such as: Title number, Chapter number, Track number, Elapsed Time, Mode, Audio, Angle, and Subtitle languages. Press this button again to turn off the information display.

During DVD/CD playback, you may edit the chapter and track.

REPEAT

Press REPEAT repeatedly to select different repeat modes.

DVD: Repeat Chapter, Repeat Title, and All.
VCD PBC off/CD/JPEG/MP3: Repeat Track and All.

A-B

To play certain section within the video or song, press A-B button to set the start-point. Then, press A-B button again to set the end point and complete the setting. The selected section will be played repeatedly.

Press A-B button the third time to cancel this function.

The end point cannot be set until 5 seconds of playback has elapsed from the start point.

SEARCH

During playback, press SEARCH button to edit Title, Chapter, and Time.

Press ◀/▶ and OK button on the remote control to select Title, Chapter, or Time. Then press the numeric buttons or ▲/▼ and then press OK. The playback will skip to the desired location.

For Time Search, press ▲/▼ to select Title or Chapter time search.

SUBTITLE

Press this button repeatedly and the screen will display "X/XX XXX" or "Off". The "X" indicates the current number of this language; "XX" indicates the total number of language; "XXX" indicates the language.

The number of available languages depends on the disc.

RETURN

Press this button to return to the previous on-screen menu in setup menu such as External Memory Information, Parental Control, Country Code, etc.

During MP3/JPEG/VIDEO playback, press RETURN once, it will return back to Media Center page.

During VCD disc playback and PBC On is selected, press this button to return to PBC Menu.

ANGLE

During playback, press this button to change the angle of the picture. The screen will display "Angle X/X." The first "X" indicates the current number of angle, and the second "X" indicates total number of angle.

Not all Blu-ray Disc™ or DVD has the multi-

angle feature. The screen will take around 5 seconds to change.

TOP MENU

You may press this button at any time, and the Blu-ray Disc™ player or DVD video disc playback will pop up the disc menu.

POP MENU/MENU

During Blu-ray Disc™ playback, press POP MENU/MENU to display the disc title, and the playback will not be stopped even the menu is on the screen.

1. Press the ▲/▼/◀/▶ buttons to select an option, then press OK to confirm.

2. Press POP MENU/MENU to close the menu.

During DVD playback, press POP MENU/MENU to open the disc menu.

During VCD playback, press POP MENU/MENU to switch PBC On/Off.

During displaying USB and Data Disc file content in media center, press POP MENU/MENU to add the Photo/Music/Video files to the playlist.

1. Press ▲/▼/◀/▶ buttons to select an option under the Photo/Music/Video files.

2. In the file browser, press ▶ to select the file(s) to be added to the playlist. "√" will appear beside the selected files.

3. Press POP MENU/MENU button, a pop up menu will appear, then press ▲/▼ and OK button to select "Add to Playlist" to add the files to the Playlist. "Select all" and "Clear all" options are also available. Select "Cancel" to exit the pop up menu.

All the selected files will be added to the "Playlist" folder. You can play or delete the files in the playlist.

Press POP MENU/MENU to delete the selected files in "Playlist"

SETUP

Press the SETUP button, and the screen will display some information about the player, such as:

- General Setting
- Display Setting
- Audio Setting
- System Information

PROGRAM

During CD/DVD/VCD playback, you can press this button to edit the sequence of the playlist.

BOOKMARK

During VCD/DVD/DivX® disc playback, press the BOOKMARK button to add the bookmark; press and hold for a few seconds to display the list of bookmark which you added before on the screen, then you can press the OK button to select the bookmark or CLEAR button to delete the bookmark.

AUDIO

Press AUDIO button on the remote control to select the audio streams that set within the Blu-ray™ or DVD disc.

The screen will display:

AUDIO: X / XX XXX XXXX

"X" - the Current Audio Stream Number

"XX" - The total number of Audio Stream

"XXX" - Audio Language

"XXXX" - Audio Technology

MC

Press this button to play media files in the USB.

ZOOM

Press ZOOM button repeatedly to Zoom in/out playback in the video.

Zoom mode : Zoom 2x -> Zoom 3x -> Zoom

4x -> Zoom 1/2 -> Zoom 1/3 -> Zoom 1/4.

DIGEST

During playback of JPEG disc, press DIGEST to view a page of 12 thumbnail images.

- Use ▲/▼/◀/▶ to select an image.

Press OK to view the selected image in full-screen and subsequent images will be displayed one after another automatically.

- Press PREV |◀◀ / NEXT ▶▶| to view the previous or next thumbnail screen.

2nd AUDIO

Press 2nd AUDIO button to open the secondary audio of secondary video(PIP's sub-window video).

OSC

Press OSC to open On Screen Control menu during playback. In this menu, you can make some playback-related control.

The on screen control contains following items:

[Title]: The title in current playback/titles in total. Select your desired title to playback.

[Chapter]: The chapter in current playback/chapters in total. Select your desired chapter to playback.

[Time]: View the elapsed/remaining playback time of title/chapter.

Use ▲/▼ to view: the elapsed playback time of title, the remaining playback time of title, the elapsed playback time of chapter, and the remaining playback time of chapter.

[Mode]: Select playback mode among shuffle, random, and normal.

[Audio]: The Blu-ray Disc™/DVD disc's soundtrack language. Use ▲/▼ to view the audio available in the disc and select your desired Audio type.

[Angle]: The angle view of current playback/the angles in total. Please reference Playback>Angle to see more detailed info.

Use ▲/▼ to select your desired angle view.

[Subtitle]: The Subtitle in current playback.

Use ▲/▼ to view the subtitles available in the disc and select your desired subtitle type or turn it off.

Note:

In accordance with the different discs, there would be different subtitles. Such as

Central Europe

Cyrillic

Latin I

Greek

Turkish

Hebrew

[Subtitle Style]: When you play the Blu-ray Disc™ and if it has external subtitle, you will see it in OSC menu.

[Bitrate]: Use ▲/▼ to select your desired Bitrate.

[Still Off]: Close the Still feature of DVD disc. For some DVD discs, a certain video picture will be frozen as a still picture during the process of playback to let the user has a better view of certain picture. To continue playback, select Still Off.

[Instant Search]: Instant search 30 seconds forward.

[Instant Replay]: Replay the content from 10 seconds before.

Tips:

- The specified operation for each item will vary with disc types. And some items are available only when the disc is supportable.

- The DivX® subtitle filename(.sub) has to be saved under the same filename as the movie(.avi) in the same folder (e.g. Folder A: abc.avi and abc.sub).

Blu-ray Disc™ BONUSVIEW™

Playing Secondary Video (Picture-in-Picture) and Secondary Audio is for Blu-ray Disc™ only. Secondary video can be played from a disc compatible with the Picture-in-Picture (PIP) function.

For the playback method, refer to the instructions for the disc.

1. Turn on secondary video by pressing the PIP button.

2. Press the 2nd AUDIO button to select the secondary audio, and select an option except Off. The secondary audio is opened, you can hear the disc secondary video sound.

In order to hear the secondary audio, the PIP feature on the disc must be turned on.

3. Press the PIP button again to turn off the secondary video.

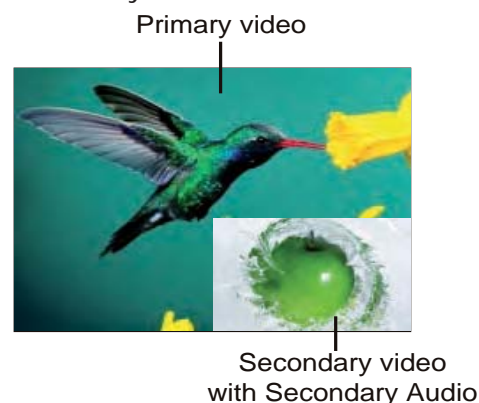

This function is not available when the primary video is played in Search, Slow-Motion, or Frame-by-Frame or Fast Forward/Reverse mode.

To listen to the secondary audio, the digital audio output must be set to "Re-encode" or "PCM". Otherwise, only the primary audio can be heard.

Note:

-Not all the Blu-ray™ discs can support this function.

6 Customizing

This section describes the various setting option of this Blu-ray Disc™ player.

If the setup option is greyed out, it means the setting cannot be changed at the current state.

General Setting

1. Press SETUP button on the remote control. The Setup Menu appears.

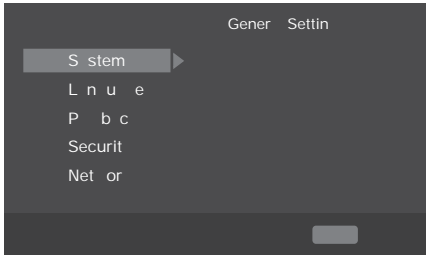

2. Press ▼ to select an option, then press ► to access.
3. Press ▲/▼ to select a setup option and press ►.
4. Select the setting you wish to change and press OK to confirm.
 - Press ◀ to return to the previous menu.

[System]

To change the following system option to personalize your Blu-ray Disc™ player.

- **[Screen Saver]**
Turn On or Off the screen saver mode. It helps to protect the TV screen.
{ **On** } – Set the screen saver active after approximately 5 minutes with no operation.
- The Blu-ray Disc™ player will switch to standby mode if there is no operation after the screen saver is engaged for approximately 15 minutes.
{ **Off** } – Turn off the screen saver mode.
- **[Disc Auto Playback]**
Turn On or Off the disc automatic playback switching mode.
{ **On** } – The disc playback automatically after loading.
{ **Off** } – Turn off disc auto playback mode.
- **[CEC]**
This player supports REGZA-LINK which uses the HDMI CEC (Consumer Electronics Control) protocol. You can

use one single remote control to control all REGZA-LINK-compliant devices that are connected through HDMI connectors.

{ **On** } - Turns on REGZA-LINK features.

-With CEC on, during TV standby with the Blu-ray Disc™ player on, pressing SETUP, PLAY/PAUSE will power on the TV. When you turn the TV off, this unit will automatically turn off.

{ **Off** } - Disables REGZA-LINK features.

- **[Load Default]**

Reset all settings of Blu-ray Disc™ player to initial default state.

- Follow the instruction on the TV screen to confirm the default setting operation.

1. Select **Load Default**.

2. A dialogue box pops up shown as below. Select OK.

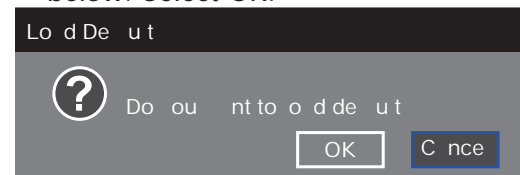

3. It may take awhile when loading default is in progress. Please wait...

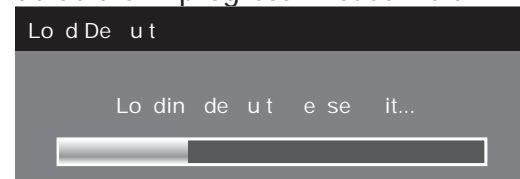

4. TV will display as follow:

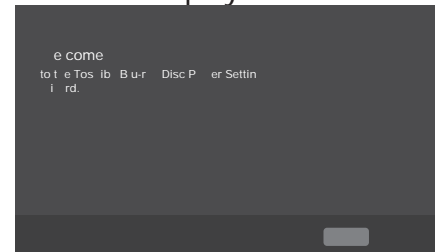

5. Press OK, enter language setting. Press ▲/▼ to select a language option.

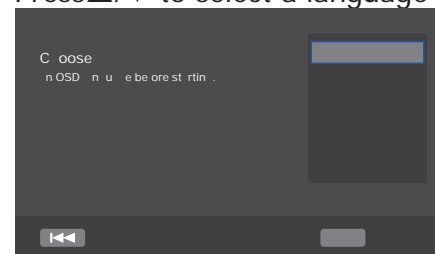

6. Press OK, enter Resolution setting.

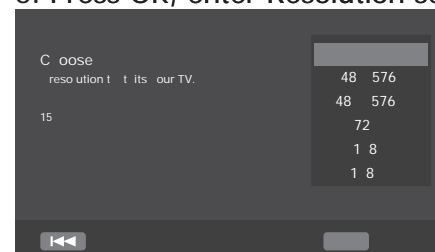

Note:

When the player is connected to both VIDEO OUTPUT jack and HDMI OUTPUT jack, resolution set to 720p/1080i/1080p, there will be no output through VIDEO OUTPUT jack.

Press ▲/▼ to select an option. Press OK. Select "Yes" or "No" using ▲/▼.

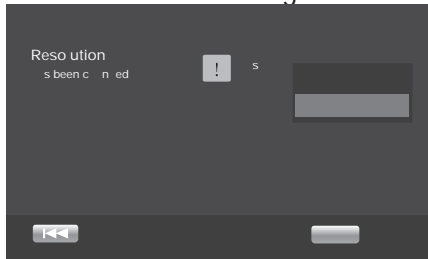

7. Press OK, enter Aspect ratio setting.

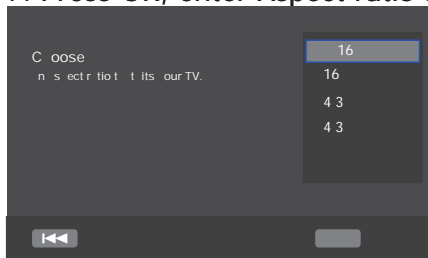

Press ▲/▼ to select an option. Press OK.

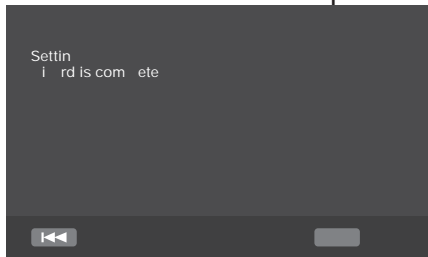

8. Press OK to return to [General Setting] Menu.

- **[Upgrade]**

For software upgrades to enhance performance, you could select the following upgrade method and start to upgrade.

- **{ Disc }/{USB Storage}**

Upgrade the software from the disc or USB Flash device.

1. Insert the disc or connect the USB Flash device which contains the upgrade file package.
2. Follow the instruction on the TV screen to confirm upgrade operation.
 - The system will reboot after 5 seconds or OK key is pressed.

Notes:

- If set [Disc Auto Playback] to [Off], after you insert the disc that contains the upgraded information to upgrade system, you have to start upgrade from this option of SETUP Menu.
- If the upgrade file package did not pass the verification, error prompt is displayed, check the package again (such as the package is not complete)
- Make sure the firmware version is not an old version.

- When you upgrade the system using USB Flash device, you should make a new folder named UPG_ALL, and copy the upgrade file into this folder.

- **[External Memory]**

External Memory would be used in BD-Live™ function. When you plug in the USB flash device which has at least 1GB free space to play BD-Live™ function, the Blu-ray Disc™ system would make a directory named BUDA automatically. Information will display the Free size.

1. Press OK.
2. Follow the instruction on the TV screen to select {Information}.

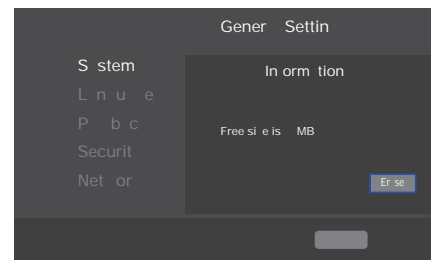

3. Press OK to select "Erase", the data in the BUDA folder will be cleared.

- **[Blu-ray Disc Logo]**

Turn On or Off the Blu-ray Disc™ Logo on the front panel. You can control the Blu-ray Disc™ Logo lights on or off.

- **[Language]**

Set up the OSD(On-Screen Display), Menu, Audio and Subtitle default language for the player.

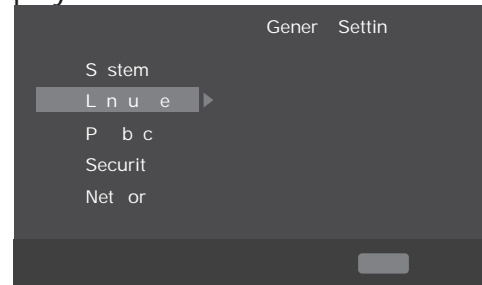

- **[OSD]**

Select the default on-screen display language.

- **[Menu]**

Select the menu language.

- **[Audio]**

Select the default audio language.

- **[Subtitle]**

Select the default subtitle language.

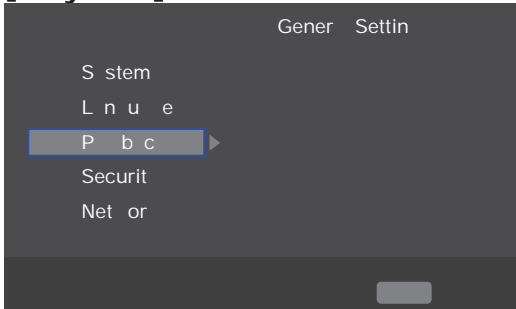
[Playback]

- **[Angle Mark]**

Some Blu-ray discs/DVDs contain the scenes recorded with multiple angles, which allow you to enjoy the videos with your desired angles, therefore the angle mark is displayed only when the Blu-ray Disc™/DVD disc is supportable for multi-angle and Angle Mark is set to ON.

{On} – Display the angle mark.

{Off} – Hide the angle mark.

- **[PIP Mark]**

The Picture -In- Picture (PIP) mode display two pictures on the TV screen at the same time, the full screen picture is called Main Window and the small inset window is called Sub Window. The PIP mark is displayed when in PIP mode and PIP Mark is set to ON.

{On} – Display the PIP mark.

{Off} – Hide the PIP mark.

- **[Secondary Audio Mark]**

{On} – Display Secondary Audio Mark.

{Off} – Hide the Secondary Audio Mark.

- **[Last Memory]**

If you open the disc tray or switch this player to standby state during normal playback, the Blu-ray Disc™ Player can memorize the end playing point, the player will start playback from the memorized point next time.

{On} – Active Last Memory feature.

{Off} – Disable Last Memory feature.

Note:

-Not all the Blu-ray™ discs can support this function.

- **[PBC]**

VCD2.0 has PBC control (Playback Control) menu, which allow you to interact with the system via menu.

{On} – Display playback control menu, use NUMBER keys to select desired option.

{Off} – Hide playback control menu and start playback from track1 automatically.

- **[Closed Caption]**

Allow people who are deaf or hearing impaired, to have access to television programming by displaying the audio

portion of a television programme as text on the screen.

{On} – Display the Closed Caption.

{Off} – Hide the Closed Caption.

- **[DivX(R) VOD DRM]**

The DivX(R) VOD DRM means DivX(R) Video on Demand Digital Right Management.

DivX® is the name of a revolutionary new video codec which is based on the new MPEG-4 compression standard for video. You will be able to play DivX® movies using this player.

You can only play DivX® videos that were rented or purchased with the DivX® registration code of this product.

Select the DivX(R) VOD DRM option, you can find this product's registration code.

To learn more please visit

<http://www.divx.com/vod>.

- **[Security]**

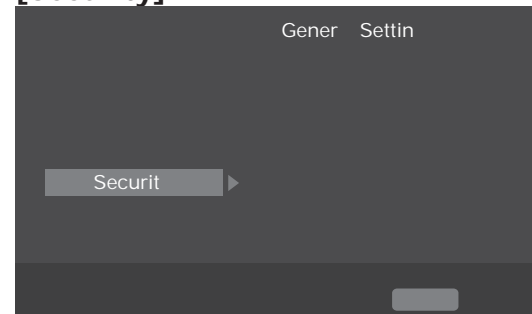

- **[Change password]**

Follow the instruction on the TV set or change the password for locked discs and play restricted Blu-ray discs/DVDs.

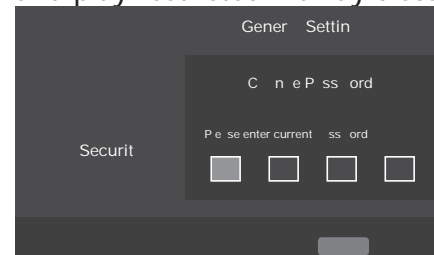

1. Use NUMBER keys to enter four digit old password. The default password is "0000".

2. Enter the new password

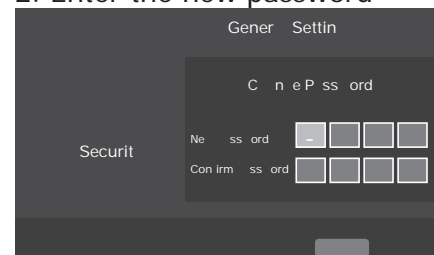

3. Enter the new password again to confirm.

- **[Country Code]**

This ensures that you will be able to see the scenes intended for your current residential Country/Area.

Use NUMBER Keys to enter your password, then you can choose your Country/Area.

- **[Parental Control]**

Restricts access to discs that are unsuitable for children. These discs must be recorded with rating.

1. Press OK.
2. Use NUMBER keys to enter the password

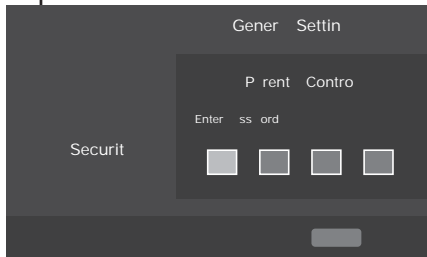

3. Select a rating level, then press OK.

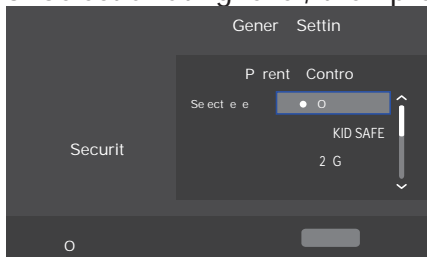

13	13
17	17

Notes:

- Rated discs above the level you set in [Parental Control] require a password to be entered.

- The ratings are country-dependent. To allow all discs to play, select 'Off'.

- **[Network]**

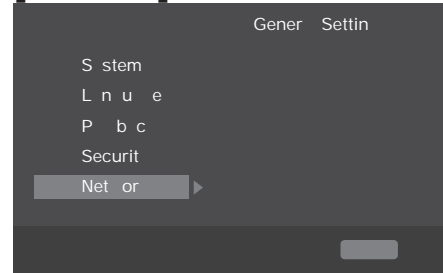

To enjoy BD-Live™ bonus contents, setup the network connection.

Note:

- Ensure that the network cable is properly connected and the router is switched on.

1. Connect the Blu-ray Disc™ player to the broadband modem or router.
2. In the Setup menu, select [Network], then press ►.

3. Select [IP Setting] in the menu, then press OK to select [Auto]. An IP address is obtained automatically.

If no IP address is obtained, select [Manual] to input IP Address, Subnet Mask, Default Gateway, DNS1/DNS2 and press OK to re-connect again to the network. It will try to obtain the IP address again.

4. Press RETURN or press OK to exit.

Notes:

- During [Manual] mode, if the number is entered incorrectly, press ▼ to erase the number.

- A contract with the provider is needed to connect to the Internet.

- This player does not support automatic detection of cross-cables. Use the straight (standard) LAN cable.

- Loading BD-Live™ content from the internet may take some time, depending on the file size and the speed of the internet connection.

- **[IP Setting]**

{Auto} – Auto obtain network information.

{Manual} – Manual setup network information.

- **[Connection Test]**

Display Network connection status information.

- **[BD-Live Connection]**

{Permitted} – During playback of BD-Live™ disc, the disc may automatically download all information from appointed network.

{Partial Permitted} – During playback of BD-Live™ disc, the disc may automatically download partial of the information from appointed network.

{Prohibited} – Disable downloading information from network.

- **[Information]**

Display all Network Information.

Display Setting

1. Press SETUP, [**General Setting**] menu is displayed.
2. Press ► to select [**Display Setting**], then press ▼.
3. Select an option, press ► to access.

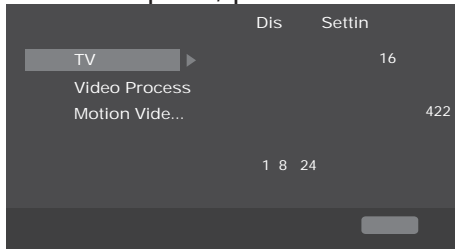

4. Press ▲/▼ to select a setup option and press ►.
5. Select the setting you wish to change and press OK to confirm.
 - Press ◀ to return to the previous menu.
 - Press SETUP to exit the menu.

[TV]

- **[TV Screen]**

Select the screen format according to how you want the picture to appear on the TV.

{**16:9 Full**} – for a disc with the aspect ratio of 4:3, the output video is stretched into 16:9 full screen.

{**16:9 Normal**} – for a disc with the aspect ratio of 4:3, the output video is resized vertically to match what will be seen on the display.

{**4:3 Pan&Scan**} – for standard TV, Display a wide picture on the entire screen and cuts off the redundant portions.

{**4:3 Letterbox**} – for standard TV, Display a wide picture with two black borders on the top and bottom of 4:3 screen.

- **[Resolution]**

Select a video output resolution that is compatible with your TV display capability.

{**Auto**} – Select the most suitable resolution according to the TV.

{**480i/576i**}, {**480p/576p**}, {**720p**}, {**1080i**}, {**1080p**}

– Select a video resolution setting that is best supported by the TV. See TV manual for details.

Note:

-When resolution is set to 720p/1080i/1080p:

(1) If only CVBS connected, the resolution of CVBS video output will be set to 480i/576i automatically.

(2) If HDMI and CVBS are both connected, there will be no CVBS video output, instead, a message will be shown as follows:

Out Of Range:Check Display Resolution

- **[Color Space]**

Select a predefined Colour space of picture.

{**RGB**} – Select RGB Colour space.

{**YCbCr**} – Select YCbCr Colour space.

{**YCbCr422**} – Select YCbCr422 Colour space.

{**Full RGB**} – Select Full RGB Colour space.

- **[HDMI Deep Color]**

This feature is available only when the display device is connected by a HDMI cable, and when it supports deep Colour feature.

{**30 bits**} – Output 30 bits Colour.

{**36 bits**} – Output 36 bits Colour.

{**Off**} – Output standard 24 bits Colour.

Note:

-When the Colour space is "YCbCr422", even if HDMI Deep Colour is set to 30bits/36bits, it is not output with Deep Colour.

- **[HDMI 1080/24p]**

{**On**} – Enable 1080/24p video resolution setting.

{**Off**} – Disable 1080/24p video resolution setting.

Notes about HDMI 1080/24p:

If you want the 24Hz output, it should fulfill below 3 conditions:

1. TV supports the 24Hz display;

2. Player choose the 24Hz option in the setup menu;

3. Media must be the 24Hz video.

Notes

- This resolution becomes effective only when the playing Blu-ray Disc™ contents are Film source.

- During HDMI 1080/24p playback, there will be no composite output.

- **[HDMI 3D]**

Turn on or off the 3D function.

{**Auto**} – Opening the 3D function of player.

{**Off**} – Turn off the 3D function.

When you play a side by side 3D disc, which is a kind of 3D disc and it is made up of two frames, the player will playback this disc and export the content based on the TV's settings. So if you want to do some settings, such as OSC or program, please ensure that the 3D TV's setting is correct.

Note: If you do some 3D TV's setting during 3D disc playback, the TV screen may be abnormal. To recover, load the 3D TV's default setting first.

[Video Process]

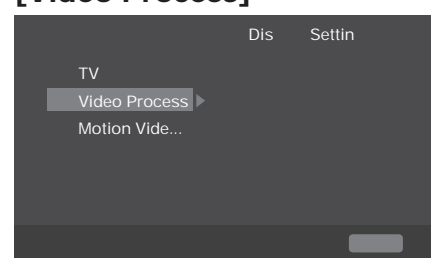

- **[Video Adjust]**
Select a predefined setting of the video.
1. Press OK .
2. Press ◀/▶ to adjust the video Brightness, Contrast, Hue and Saturation.
{**Brightness**} - press ◀/▶ to adjust the brightness of display, goes left means dark and right means bright.
{**Contrast**} - press ◀/▶ to adjust the contrast of display, goes left means low contrast and right means high contrast.
{**Hue**} - press ◀/▶ to adjust the Hue of display, goes left means low hue and right means high hue.
{**Saturation**} - press ◀/▶ to adjust the saturation of display, goes left means low Saturation and right means high saturation.
3. Press RETURN to exit.



- **[Sharpness]**
Select the level of sharpness: High, Middle, Low
{**High**} - Select High sharpness level
{**Middle**} - Select Middle sharpness level
{**Low**} - Select Low sharpness level

[Motion Video Process]

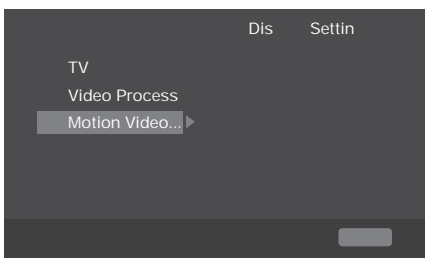

- **[Video Mode]**
Select the output mode of video, options include: Standard, Vivid, Cinema, Custom, these can change the output display.
{**Standard**} - output video signal without any processing and in standard mode.
{**Vivid**} - output video signal in vibrant Colour mode.
{**Cinema**} - output video signal in cinema mode.
{**Custom**} - you can define your own video mode by adjusting the video Brightness, Saturation, Hue, Contrast, Sharpness and CTI.

- **[Color Adjust]**
You can define your own Colour adjustment when you select the Custom video mode and you can adjust the Colour of red, green, blue, yellow, cyan and magenta.
{**Red**} - Define your own red Colour by adjusting the brightness, saturation and hue.
{**Green**} - Define your own green Colour by adjusting the brightness, saturation and hue.
{**Blue**} - Define your own blue Colour by adjusting the brightness, saturation and hue.
{**Yellow**} - Define your own yellow Colour by adjusting the brightness, saturation and hue.
{**Cyan**} - Define your own cyan Colour by adjusting the brightness, saturation and hue.
{**Magenta**} - Define your own magenta Colour by adjusting the brightness, saturation and hue.
- **[Noise Reduction]**
Reduces the noise of the playback picture.
{**0**} - Shows the original picture as recorded.
{**1**} - Executes 3D noise reduction which detects and deletes the noise by comparing each picture frames.
{**2**} - Executes MPEG noise reduction which reduces the block noise and mosquito noise on the subtitles on the movie.
{**3**} - Executes both MPEG noise reduction and 3D noise reduction.

Audio Setting

1. Press SETUP, [**General Setting**] menu is displayed.
2. Press ▶ to select [**Audio Setting**], then press ▼ .
3. Select an option, press ▶ to access.

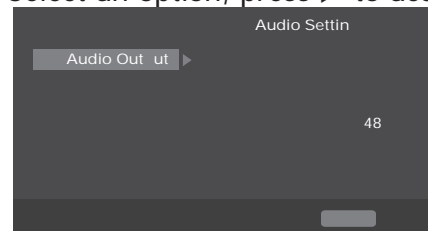

4. Press ▲/▼ to select a setup option and press ▶ .
5. Select the setting you wish to change and press OK to confirm.
 - Press ◀ to return to the previous menu.
 - Press SETUP to exit the menu.

- **[Audio Output]**
 - **[Spdif]**
Select the output mode of COAXIAL jack, options include Bitstream, PCM, Re-encode and Off.
{**Bitstream**} – Output digital signal without any processing.
{**PCM**} – Output digital signal with processing, only two channels export.
{**Re-encode**} – Auto select signal type from COAXIAL jack according to the Audio stream on disc.
{**Off**} – No output for S/PDIF.
 - **[HDMI]**
Select the output mode of HDMI Out jack, options include Bitstream, PCM, Re-encode and Off.
{**Bitstream**} – Output HDMI digital signal without any processing.
{**PCM**} – Output HDMI digital signal with processing, only two channels export.
{**Re-encode**} – Auto select signal type from HDMI Out jack according to the Audio stream on disc.
{**Off**} – No output for HDMI.
 - **[Down_samp]**
Select the digital audio signal sampling frequency.
{**48K**} – For discs recorded at sampling rate of 48 kHz.
{**96K**} – For discs recorded at sampling rate of 96 kHz.
{**192K**} – For discs recorded at sampling rate of 192 kHz.
 - **[DRC]**
Select the Dynamic Range Control mode which makes it available to listen to a movie at a low volume without losing sound clarity.
{**Off**} – Non-dynamic range compress.
{**On**} – Dynamic range compress.
{**Auto**} – Adjust the DRC according to input audio.
The setting of Auto is effective for Dolby TrueHD.

System Information

1. Press SETUP, [**General Setting**] menu is displayed.
2. Press ► to select [**System Information**].
 - The current software version and MAC address will be displayed.
 - Press ◀ to return to the previous menu.
 - Press SETUP to exit the menu.

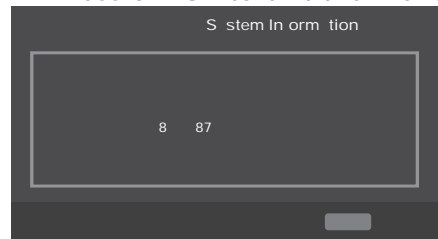

7 Specification

Playable media

This product can play:

- Blu-ray Disc™-Video, BD-R/RE2.0, BDAV
- DVD, DVD-Video, DVD+R/+RW, DVD-R/-RW, DVD+R/-R DL (Dual Layer)
- Video CD/SVCD
- Audio CD, CD-R/CD-RW
- AVCHD, AVCREC disc
- USB flash device

Video

- Signal system: PAL/NTSC
- Composite video output: 1Vp-p (75 ohm).
- HDMI Output: 480i/576i, 480p/576p, 720p, 1080i, 1080p, 1080/24p

Audio

- 2 Channel analogue output
 - Audio L&R : 2 Vrms (< 2.2 kohm)
 - Signal-to-noise Ratio \geq 95 dB
 - THD+N 1kHz \leq -85 dB
 - Dynamic Range 1kHz \geq 85 dB
 - Crosstalk 1kHz \leq -95dB
- Digital output (Coaxial): 0.5 Vp-p (75 ohm)
- HDMI output

LAN

- LAN terminal 10BASE-T/100BASE-TX

USB

- USB 1.1 / USB 2.0 Full-speed / USB 2.0 High-speed
- Supporting range: flash disk, card reader, 4 ports USB HUB, USB Mass Storage Class Device.
- Supported file system: FAT32
- Maximum size supported: 32GB
- Does not support unpowered HDD

MP3 tracks

- Supported file extension: '.mp3'
- Supported audio codec : MP3
- ISO format
- Supported corresponding bitrate: 8kbps-320 kbps
- Supported sampling frequencies: 32kHz, 44.1kHz, 48kHz

JPEG

- Supported file extensions: '.jpg' or '.jpeg'
- JPEG/ISO format
- Does not support Picture CD

DivX®

- Supported file extension: '.DIVX'
- DivX HD

Main Unit

- Power supply rating: 100V-240V 50/60Hz
- Power consumption: 18W
- Power consumption in standby mode: <1W
- Dimensions (w x h x d): 430×42.5×200 (mm)
- Net Weight: 1.54 kg
- Operating temperature: 5°C to 35°C
- Operating humidity: Less than 80 % (no condensation)

Accessories supplied

- Remote control and Size 'R03' carbon zinc batteries (Two)
- HDMI cable
- Owner's manual

8 Troubleshooting

If you experience any of the following difficulties while using this unit, check the list below before consulting your nearest TOSHIBA dealer.

Problem	Tip
No reaction to the remote control.	Connect the product to the power outlet.
	Point the remote control at the product.
	Insert the batteries correctly.
	Insert new batteries in the remote control.
No video signal on the display device.	Turn on the TV.
	Set the TV to the correct external input.
	Select the correct video resolution.
	Set TV System correctly.
No video output through VIDEO OUTPUT jack.	Set Resolution of HDMI to 480i/576i or 480p/576p
Incorrect or no audio / video signal on the amplifier/display device via HDMI cable.	If the unit is connected to the unauthorized display device with an HDMI cable, the audio/video signal may not be output.
	Ensure the amplifier/display devices setting match the Blu-ray Disc™ player.
No high-definition video signal on the TV.	Does the disc contain high-definition video? High-definition video is not available when the disc does not contain it.
	Does the TV support high-definition video? High-definition video is not available when the TV does not support it.
No audio signal from the loudspeakers of the TV.	Assign the audio input of the TV to the corresponding video input.
No audio signal from the loudspeakers of the audio system.	Turn on the audio system.
	Set the audio system to the correct external input.
	Increase the volume level of the audio system.
No 3D effectiveness	Set HDMI 3D to Auto.
	Connecting by HDMI cable.
	Connecting to a 3D TV.
	Playback a 3D disc.
	Wear 3D glasses.

Cannot play back a disc.	Make sure that the Blu-ray Disc™ Player supports the disc.
	Make sure that the Blu-ray Disc™ player supports the region code of the DVD or Blu-ray Disc™.
	For DVD+RW/+R or DVD-RW/-R, make sure that the disc is finalized.
	Clean the disc.
Cannot play back JPEG files from a disc.	Make sure that the disc was recorded in the UDF, ISO9660 or JOLIET format.
Cannot play DivX® files	Make sure that the file was recorded in the H.264 or MPEG-4 format.
Cannot play MP3 files from a disc.	Make sure that the disc was recorded in the UDF, ISO9660 or JOLIET format.
	Make sure that the bit rate of the MP3 files is between 8 and 320 kbps.
	Make sure that the sample rate of the MP3 files is 32kHz, 44.1kHz or 48kHz.
Cannot find a JPEG file.	Make sure that the selected group (folder) does not contain more than 9,999 files for DVD and 999 files for CD.
	Make sure that the file extension is .jpg, .JPG, .jpeg or .JPEG.
Cannot find a MP3 file.	Make sure that the selected folder does not contain more than 9,999 files for DVD and 999 files for CD.
	Make sure that the file extension is .mp3 or .MP3.
Cannot upgrade SW	When you upgrade the system with USB Flash device, you should make a new folder named UPG_ALL, and copy the upgrade file into this folder.
The USB Flash Device cannot be played	Use USB Flash Device corresponding to the Mass Storage Class Driver.
Sometimes the options of setup menu cannot be selected.	When playing a DVD disc or Blu-ray Disc™, press STOP button once, the player will go into stop resume mode, meanwhile you cannot change some settings in setup menu such as language subitem menu, audio, subtitle etc. If you want to change that, press STOP button twice, the player will go into full stop mode, then you can do it.

9 Glossary

Aspect ratio

Aspect ratio refers to the length to height ratio of TV screens. The ratio of a standard TV is 4:3, while the ratio of a high definition or wide TV is 16:9. The letterbox allows you to enjoy a picture with a wider perspective on a standard 4:3 screen.

Blu-ray Disc™

Blu-ray Disc™ is a next generation optical video disc capable of storing five times more data than a conventional DVD. The large capacity makes it possible to benefit from the features such as high-definition videos, multichannel surround sound, interactive menus and so on.

BONUSVIEW™

This is a Blu-ray Disc™-Video (Final Standard Profile or Profile 1.1) that supports interactive content encoded on the disc, such as picture-in-picture. This means you can play the primary video and secondary video simultaneously.

Digital Audio

Digital Audio is a sound signal that has been converted into numerical values. Digital sound can be transmitted through multiple channels. Analogue sound can only be transmitted through two channels.

DivX®

ABOUT DIVX VIDEO:

DivX® is a digital video format created by DivX, Inc. This is an official DivX Certified® device that plays DivX video. Visit divx.com for more information and software tools to convert your files into DivX video.

ABOUT DIVX VIDEO-ON-DEMAND:

This DivX Certified® device must be registered in order to play purchased DivX Video-on-Demand (VOD) movies. To obtain your registration code, locate the DivX VOD section in your device setup menu. Go to vod.divx.com for more information on how to complete your registration.

DivX®, DivX Certified® and associated logos are trademarks of DivX, Inc. and are used under license.

For HD Test Kit 1080p v1.1 and later: DivX Certified® to play DivX® video up to HD 1080p, including premium content.

Dolby® Digital

The system to compress digital sound developed by Dolby Laboratories. It offers you sound of stereo (2ch) or multichannel audio.

Dolby® Digital Plus

Dolby Digital Plus is the next generation digital audio compression technology developed as an extension to Dolby Digital. Blu-ray Disc™ supports 7.1 multi-channel surround sound output.

Dolby® TrueHD

Dolby TrueHD is a lossless coding technology developed for next generation optical discs. Blu-ray Disc™ supports 7.1 multi-channel surround sound output.

DTS®

DTS is a multi-channel surround sound system. By connecting to DTS decoder, you can enjoy movie dynamic and realistic sound like movie theater. DTS surround sound technologies were developed by DTS, Inc.

DTS-HD®

DTS-HD is a lossless coding technology developed as an extension of the original DTS Coherent Acoustics format. Blu-ray Disc™ supports 7.1 multi-channel surround sound output.

DTS-HD Master Audio™

A disc encoded with DTS-HD Master Audio delivers ALL of the information from the original master recording — bit-for-bit, it's identical to what the sound engineers laid down. Audio doesn't get any better than this.

HDCP

High-bandwidth Digital Content Protection. This is a specification that provides a secure transmission of digital contents between different devices (to prevent unauthorized copyright.)

HDMI®

High-Definition Multimedia Interface (HDMI) is a high-speed digital interface that can transmit uncompressed high definition video and digital multichannel audio. It delivers high quality picture and sound quality. HDMI is fully backward compatible with DVI. As required by the HDMI standard, connecting to HDMI or DVI products without HDCP (High bandwidth Digital Content Protection) will result in no Video or Audio output.

JPEG

A very common digital still picture format. A still-picture data compression system proposed by the Joint Photographic Expert Group, which features small decrease in image quality in spite of its high compression ratio. Files are recognized by their file extension '.jpg' or '.jpeg.'

LAN (Local Area Network)

A group of linked devices in a company, school or home. Indicates the boundaries of a particular network.

Local storage

This storage area is used as destination for storing additional contents from BD-Live™ enabled Blu-ray Disc™-Video.

MP3

A file format with a sound data compression system. MP3 is the abbreviation of Motion Picture Experts Group 1 (or MPEG-1) Audio Layer 3. With the MP3 format, one CD-R or CD-RW can contain about 10 times more data than a regular CD.

PBC

Playback Control. A system where you navigate through a Video CD/Super VCD with on-screen menus that are recorded onto the disc. You can enjoy interactive playback and search.

PCM

Pulse Code Modulation. A digital audio encoding system.

Region code

A system that allows discs to be played only in the region designated. This unit only plays discs that have compatible region codes. You can find the region code of your unit on the product label. Some discs are compatible with more than one region (or ALL regions).

License Information on the Software Used in This Product

This document is statement purpose only. Not concerned with operation of this product.

The software pre-installed in this product consists of multiple, independent software components. Each software component is copyrighted by a third party. This product uses software components that are distributed as freeware under a third-party end-user license agreement or copyright notice (hereinafter referred to as a "EULA"). Some EULAs require that the source code of the applicable component be disclosed as the condition for distributing the software component in executable format. You can check the software components subject to such EULA requirements on the following website:

Website: <http://www.regza-asia.com/contact/feedback.asp>

TOSHIBA provides a warranty for this product you have purchased under conditions set forth by TOSHIBA. However, some of the software components distributed under an EULA are made available for use by the user on the assumption that they are not copyrighted or warranted by a third party. These software components are licensed to the user free of charge and therefore not covered by any warranty within the scope of the applicable laws. These software components are not subject to any copyrights or other third-party rights and are provided in "as is" condition without any warranty, whether express or implied. "Warranty" here includes, but not limited to, an implied warranty for marketability or fitness for specific uses. All risks associated with the quality or performance of these software components are assumed by the user. TOSHIBA shall not be liable whatsoever for any cost of repair or correction or other incidental expense incurred in connection with a defect found in any of these software components. Unless specified under the applicable laws or in a written agreement, a party who changes or redistributes the software with consent from the copyright holders or based on the aforementioned licenses shall not be held liable whatsoever for any loss arising from the use of or inability to use such software components. The same applies even when the copyright holders or relevant third parties have been informed of the possibility of such loss. "Loss" here includes normal, special, incidental and indirect loss (including, but not limited to, the loss of data or its accuracy; loss incurred by the user or any third party; and interface incompatibility with other software). Please read each EULA for details on the use conditions and items that must be observed regarding these software components.

The table below lists the software components pre-installed in this product, which are subject to EULAs. The user should read the applicable EULAs carefully before using these software components. The EULAs are exhibited in their original text (English) as exactly written by the respective parties.

Project name	Project license
Linux kernel	GPLv2
SquashFS	GPLv2
Busybox	GPLv2
U-boot	GPLv2
gcc libgcc	GPLv3.txt and gcc-exception.txt (GPLv3 with GCC Runtime Library Exception)
gcc libstdc++	GPLv3.txt and gcc-exception.txt (GPLv3 with GCC Runtime Library Exception)
glibc	LGPLv2.1
LIRC	GPLv2
International Components for Unicode	ICULicense.txt
OpenSSL	openssl.txt
zlib	zlib.txt
FreeType	FreeType.txt
Expat	expat.txt
cURL	libcurl.txt
Independent JPEG group	libjpeg.txt
c-ares	c-arse.txt
mtd-utils	GPLv2
libmtp	LGPLv2.1
libusb	LGPLv2.1
libusb-compat	LGPLv2.1
Unicode Bidirectional Algorithm	Unicode_Bidirectional_Algorithm.txt
HarfBuzz	HarfBuzz.txt

GNU GENERAL PUBLIC LICENSE

Version 2, June 1991

Copyright (C) 1989, 1991 Free Software
Foundation, Inc.,51 Franklin Street, Fifth Floor, Boston, MA
02110-1301 USAEveryone is permitted to copy and distribute
verbatim copiesof this license document, but changing it is
not allowed.

Preamble

The licenses for most software are designed to take away your freedom to share and change it. By contrast, the GNU General Public License is intended to guarantee your freedom to share and change free software--to make sure the software is free for all its users. This General Public License applies to most of the Free Software Foundation's software and to any other program whose authors commit to using it. (Some other Free Software Foundation software is covered by the GNU Lesser General Public License instead.) You can apply it to your programs, too.

When we speak of free software, we are referring to freedom, not price. Our General Public Licenses are designed to make sure that you have the freedom to distribute copies of free software (and charge for this service if you wish), that you receive source code or can get it if you want it, that you can change the software or use pieces of it in new free programs; and that you know you can do these things.

To protect your rights, we need to make restrictions that forbid anyone to deny you these rights or to ask you to surrender the rights. These restrictions translate to certain responsibilities for you if you distribute copies of the software, or if you modify it.

For example, if you distribute copies of such a program, whether gratis or for a fee, you must give the recipients all the rights that you have. You must make sure that they, too, receive or can get the source code. And you must show them these terms so they know their rights.

We protect your rights with two steps: (1) copyright the software, and (2) offer you this license which gives you legal permission to copy, distribute and/or modify the software.

Also, for each author's protection and ours, we want to make certain that everyone understands that there is no warranty for this free software. If the software is modified by someone else and passed on, we want its recipients to know that what they have is not the original, so that any problems introduced by others will not reflect on the original authors' reputations.

Finally, any free program is threatened constantly by software patents. We wish to avoid the danger that redistributors of a free program will individually obtain patent licenses, in effect making the program proprietary. To prevent this, we have made it clear that any patent must be licensed for everyone's free use or not licensed at all.

The precise terms and conditions for copying, distribution and modification follow.

GNU GENERAL PUBLIC LICENSE
TERMS AND CONDITIONS FOR COPYING,
DISTRIBUTION AND MODIFICATION

0. This License applies to any program or other work which contains a notice placed by the copyright holder saying it may be distributed under the terms of this General Public License. The "Program", below, refers to any such program or work, and a "work based on the Program" means either the Program or any derivative work under copyright law: that is to say, a work containing the Program or a portion of it, either verbatim or with modifications and/or translated into another language. (Hereinafter, translation is included without limitation in the term "modification".) Each licensee is addressed as "you".

Activities other than copying, distribution and modification are not covered by this License; they are outside its scope. The act of running the Program is not restricted, and the output from the Program is covered only if its contents constitute a work based on the Program (independent of having been made by running the Program). Whether that is true depends on what the Program does.

1. You may copy and distribute verbatim copies of the Program's source code as you receive it, in any medium, provided that you conspicuously and appropriately publish on each copy

an appropriate copyright notice and disclaimer of warranty; keep intact all the notices that refer to this License and to the absence of any warranty; and give any other recipients of the Program a copy of this License along with the Program.

You may charge a fee for the physical act of transferring a copy, and you may at your option offer warranty protection in exchange for a fee.

2. You may modify your copy or copies of the Program or any portion of it, thus forming a work based on the Program, and copy and distribute such modifications or work under the terms of Section 1 above, provided that you also meet all of these conditions:

a) You must cause the modified files to carry prominent notices stating that you changed the files and the date of any change.

b) You must cause any work that you distribute or publish, that in whole or in part contains or is derived from the Program or any part thereof, to be licensed as a whole at no charge to all third parties under the terms of this License.

c) If the modified program normally reads commands interactively when run, you must cause it, when started running for such interactive use in the most ordinary way, to print or display an announcement including an appropriate copyright notice and a notice that there is no warranty (or else, saying that you provide a warranty) and that users may redistribute the program under these conditions, and telling the user how to view a copy of this License. (Exception: if the Program itself is interactive but does not normally print such an announcement, your work based on the Program is not required to print an announcement.)

These requirements apply to the modified work as a whole.

If identifiable sections of that work are not derived from the Program, and can be reasonably considered independent and separate works in themselves, then this License, and its terms, do not apply to those sections when you distribute them as separate works. But when you distrib-

ute the same sections as part of a whole which is a work based on the Program, the distribution of the whole must be on the terms of this License, whose permissions for other licensees extend to the entire whole, and thus to each and every part regardless of who wrote it.

Thus, it is not the intent of this section to claim rights or contest your rights to work written entirely by you; rather, the intent is to exercise the right to control the distribution of derivative or collective works based on the Program.

In addition, mere aggregation of another work not based on the Program with the Program (or with a work based on the Program) on a volume of a storage or distribution medium does not bring the other work under the scope of this License.

3. You may copy and distribute the Program (or a work based on it, under Section 2) in object code or executable form under the terms of Sections 1 and 2 above provided that you also do one of the following:

a) Accompany it with the complete corresponding machine-readable source code, which must be distributed under the terms of Sections 1 and 2 above on a medium customarily used for software interchange; or,

b) Accompany it with a written offer, valid for at least three years, to give any third party, for a charge no more than your cost of physically performing source distribution, a complete machine-readable copy of the corresponding source code, to be distributed under the terms of Sections 1 and 2 above on a medium customarily used for software interchange; or,

c) Accompany it with the information you received as to the offer to distribute corresponding source code. (This alternative is allowed only for noncommercial distribution and only if you received the program in object code or executable form with such an offer, in accord with Subsection b above.)

The source code for a work means the preferred form of the work for making modifications to it. For an executable work, complete source code means all the source code for all modules it contains, plus any associated interface defini-

tion files, plus the scripts used to control compilation and installation of the executable. However, as a special exception, the source code distributed need not include anything that is normally distributed (in either source or binary form) with the major components (compiler, kernel, and so on) of the operating system on which the executable runs, unless that component itself accompanies the executable.

If distribution of executable or object code is made by offering access to copy from a designated place, then offering equivalent access to copy the source code from the same place counts as distribution of the source code, even though third parties are not compelled to copy the source along with the object code.

4. You may not copy, modify, sublicense, or distribute the Program except as expressly provided under this License. Any attempt otherwise to copy, modify, sublicense or distribute the Program is void, and will automatically terminate your rights under this License. However, parties who have received copies, or rights, from you under this License will not have their licenses terminated so long as such parties remain in full compliance.

5. You are not required to accept this License, since you have not signed it. However, nothing else grants you permission to modify or distribute the Program or its derivative works. These actions are prohibited by law if you do not accept this License. Therefore, by modifying or distributing the Program (or any work based on the Program), you indicate your acceptance of this License to do so, and all its terms and conditions for copying, distributing or modifying the Program or works based on it.

6. Each time you redistribute the Program (or any work based on the Program), the recipient automatically receives a license from the original licensor to copy, distribute or modify the Program subject to these terms and conditions. You may not impose any further restrictions on the recipients' exercise of the rights granted herein. You are not responsible for enforcing compliance by third parties to this License.

7. If, as a consequence of a court judgment or allegation of patent infringement or for any other reason (not limited to patent issues),

conditions are imposed on you (whether by court order, agreement or otherwise) that contradict the conditions of this License, they do not excuse you from the conditions of this License. If you cannot distribute so as to satisfy simultaneously your obligations under this License and any other pertinent obligations, then as a consequence you may not distribute the Program at all. For example, if a patent license would not permit royalty-free redistribution of the Program by all those who receive copies directly or indirectly through you, then the only way you could satisfy both it and this License would be to refrain entirely from distribution of the Program.

If any portion of this section is held invalid or unenforceable under any particular circumstance, the balance of the section is intended to apply and the section as a whole is intended to apply in other circumstances.

It is not the purpose of this section to induce you to infringe any patents or other property right claims or to contest validity of any such claims; this section has the sole purpose of protecting the integrity of the free software distribution system, which is implemented by public license practices. Many people have made generous contributions to the wide range of software distributed through that system in reliance on consistent application of that system; it is up to the author/donor to decide if he or she is willing to distribute software through any other system and a licensee cannot impose that choice.

This section is intended to make thoroughly clear what is believed to be a consequence of the rest of this License.

8. If the distribution and/or use of the Program is restricted in certain countries either by patents or by copyrighted interfaces, the original copyright holder who places the Program under this License may add an explicit geographical distribution limitation excluding those countries, so that distribution is permitted only in or among countries not thus excluded. In such case, this License incorporates the limitation as if written in the body of this License.

9. The Free Software Foundation may publish revised and/or new versions

of the General Public License from time to time. Such new versions will be similar in spirit to the present version, but may differ in detail to address new problems or concerns.

Each version is given a distinguishing version number. If the Program specifies a version number of this License which applies to it and "any later version", you have the option of following the terms and conditions either of that version or of any later version published by the Free Software Foundation. If the Program does not specify a version number of this License, you may choose any version ever published by the Free Software Foundation.

10. If you wish to incorporate parts of the Program into other free programs whose distribution conditions are different, write to the author to ask for permission. For software which is copyrighted by the Free Software Foundation, write to the Free Software Foundation; we sometimes make exceptions for this. Our decision will be guided by the two goals of preserving the free status of all derivatives of our free software and of promoting the sharing and reuse of software generally.

NO WARRANTY

11. BECAUSE THE PROGRAM IS LICENSED FREE OF CHARGE, THERE IS NO WARRANTY FOR THE PROGRAM, TO THE EXTENT PERMITTED BY APPLICABLE LAW. EXCEPT WHEN OTHERWISE STATED IN WRITING THE COPYRIGHT HOLDERS AND/OR OTHER PARTIES PROVIDE THE PROGRAM "AS IS" WITHOUT WARRANTY OF ANY KIND, EITHER EXPRESSED OR IMPLIED, INCLUDING, BUT NOT LIMITED TO, THE IMPLIED WARRANTIES OF MERCHANTABILITY AND FITNESS FOR A PARTICULAR PURPOSE. THE ENTIRE RISK AS TO THE QUALITY AND PERFORMANCE OF THE PROGRAM IS WITH YOU. SHOULD THE PROGRAM PROVE DEFECTIVE, YOU ASSUME THE COST OF ALL NECESSARY SERVICING, REPAIR OR CORRECTION.

12. IN NO EVENT UNLESS REQUIRED BY APPLICABLE LAW OR AGREED TO IN WRITING WILL ANY COPYRIGHT HOLDER, OR ANY OTHER PARTY WHO MAY MODIFY AND/OR REDISTRIBUTE THE PROGRAM AS PERMITTED ABOVE, BE LIABLE TO YOU FOR DAMAGES,

INCLUDING ANY GENERAL, SPECIAL, INCIDENTAL OR CONSEQUENTIAL DAMAGES ARISING OUT OF THE USE OR INABILITY TO USE THE PROGRAM (INCLUDING BUT NOT LIMITED TO LOSS OF DATA OR DATA BEING RENDERED INACCURATE OR LOSSES SUSTAINED BY YOU OR THIRD PARTIES OR A FAILURE OF THE PROGRAM TO OPERATE WITH ANY OTHER PROGRAMS), EVEN IF SUCH HOLDER OR OTHER PARTY HAS BEEN ADVISED OF THE POSSIBILITY OF SUCH DAMAGES.

END OF TERMS AND CONDITIONS

How to Apply These Terms to Your New Programs

If you develop a new program, and you want it to be of the greatest possible use to the public, the best way to achieve this is to make it free software which everyone can redistribute and change under these terms.

To do so, attach the following notices to the program. It is safest to attach them to the start of each source file to most effectively convey the exclusion of warranty; and each file should have at least the "copyright" line and a pointer to where the full notice is found.

<one line to give the program's name and a brief idea of what it does.>

Copyright (C) <year> <name of author>

This program is free software; you can redistribute it and/or modify it under the terms of the GNU General Public License as published by the Free Software Foundation; either version 2 of the License, or (at your option) any later version.

This program is distributed in the hope that it will be useful, but WITHOUT ANY WARRANTY; without even the implied warranty of MERCHANTABILITY or FITNESS FOR A PARTICULAR PURPOSE. See the GNU General Public License for more details.

You should have received a copy of the GNU General Public License along with this program; if not, write to the Free Software Foundation, Inc., 51 Franklin Street, Fifth Floor, Boston, MA 02110-1301 USA.

Also add information on how to contact you by electronic and paper mail.

If the program is interactive, make it output a short notice like this when it starts in an interactive mode:

```
Gnomovision version 69, Copyright (C) year
name of author
```

```
Gnomovision comes with ABSOLUTELY NO
WARRANTY; for details type `show w'.
```

```
This is free software, and you are welcome
to redistribute it under certain conditions; type
`show c' for details.
```

The hypothetical commands ``show w'` and ``show c'` should show the appropriate parts of the General Public License. Of course, the commands you use may be called something other than ``show w'` and ``show c'`; they could even be mouse-clicks or menu items--whatever suits your program.

You should also get your employer (if you work as a programmer) or your school, if any, to sign a "copyright disclaimer" for the program, if necessary. Here is a sample; alter the names:

```
Yoyodyne, Inc., hereby disclaims all copyright
interest in the program 'Gnomovision' (which
makes passes at compilers) written by James
Hacker.
```

```
<signature of Ty Coon>, 1 April 1989
Ty Coon, President of Vice
```

This General Public License does not permit incorporating your program into proprietary programs. If your program is a subroutine library, you may consider it more useful to permit linking proprietary applications with the library. If this is what you want to do, use the GNU Lesser General Public License instead of this License.

LGPLv2.1

GNU LESSER GENERAL PUBLIC LICENSE
Version 2.1, February 1999

Copyright (C) 1991, 1999 Free Software Foundation, Inc. 51 Franklin Street, Fifth Floor, Boston, MA 02110-1301 USA

Everyone is permitted to copy and distribute

verbatim copies of this license document, but changing it is not allowed.

[This is the first released version of the Lesser GPL. It also counts as the successor of the GNU Library Public License, version 2, hence the version number 2.1.]

Preamble

The licenses for most software are designed to take away your freedom to share and change it. By contrast, the GNU General Public Licenses are intended to guarantee your freedom to share and change

free software--to make sure the software is free for all its users.

This license, the Lesser General Public License, applies to some specially designated software packages--typically libraries--of the Free Software Foundation and other authors who decide to use it. You can use it too, but we suggest you first think carefully about whether this license or the ordinary General Public License is the better strategy to use in any particular case, based on the explanations below.

When we speak of free software, we are referring to freedom of use, not price. Our General Public Licenses are designed to make sure that you have the freedom to distribute copies of free software (and charge for this service if you wish); that you receive source code or can get it if you want it; that you can change the software and use pieces of it in new free programs; and that you are informed that you can do these things.

To protect your rights, we need to make restrictions that forbid distributors to deny you these rights or to ask you to surrender these rights. These restrictions translate to certain responsibilities for you if you distribute copies of the library or if you modify it.

For example, if you distribute copies of the library, whether gratis or for a fee, you must give the recipients all the rights that we gave you. You must make sure that they, too, receive or can get the source code. If you link other code with the library, you must provide complete object files to the recipients, so that

they can relink them with the library after making changes to the library and recompiling it. And you must show them these terms so they know their rights.

We protect your rights with a two-step method: (1) we copyright the library, and (2) we offer you this license, which gives you legal permission to copy, distribute and/or modify the library.

To protect each distributor, we want to make it very clear that there is no warranty for the free library. Also, if the library is modified by someone else and passed on, the recipients should know that what they have is not the original version, so that the original author's reputation will not be affected by problems that might be introduced by others. Finally, software patents pose a constant threat to the existence of any free program. We wish to make sure that a company cannot effectively restrict the users of a free program by obtaining a restrictive license from a patent holder. Therefore, we insist that any patent license obtained for a version of the library must be consistent with the full freedom of use specified in this license.

Most GNU software, including some libraries, is covered by the ordinary GNU General Public License. This license, the GNU Lesser General Public License, applies to certain designated libraries, and is quite different from the ordinary General Public License. We use this license for certain libraries in order to permit linking those libraries into non-free programs.

When a program is linked with a library, whether statically or using a shared library, the combination of the two is legally speaking a combined work, a derivative of the original library. The ordinary General Public License therefore permits such linking only if the entire combination fits its criteria of freedom. The Lesser General Public License permits more lax criteria for linking other code with the library. We call this license the "Lesser" General Public License because it does Less to protect the user's freedom than the ordinary General Public License. It also provides other free software developers Less of an advantage over competing non-free programs. These disadvantages are the reason we use

the ordinary General Public License for many libraries. However, the Lesser license provides advantages in certain special circumstances. For example, on rare occasions, there may be a special need to encourage the widest possible use of a certain library, so that it becomes a de-facto standard. To achieve this, non-free programs must be allowed to use the library. A more frequent case is that a free library does the same job as widely used non-free libraries. In this case, there is little to gain by limiting the free library to free software only, so we use the Lesser General Public License. In other cases, permission to use a particular library in non-free programs enables a greater number of people to use a large body of free software. For example, permission to use the GNU C Library in non-free programs enables many more people to use the whole GNU operating system, as well as its variant, the GNU/Linux operating system. Although the Lesser General Public License is Less protective of the users' freedom, it does ensure that the user of a program that is linked with the Library has the freedom and the wherewithal to run that program using a modified version of the Library. The precise terms and conditions for copying, distribution and modification follow. Pay close attention to the difference between a "work based on the library" and a "work that uses the library". The former contains code derived from the library, whereas the latter must be combined with the library in order to run.

GNU LESSER GENERAL PUBLIC LICENSE

TERMS AND CONDITIONS FOR COPYING, DISTRIBUTION AND MODIFICATION

0. This License Agreement applies to any software library or other program which contains a notice placed by the copyright holder or other authorized party saying it may be distributed under the terms of this Lesser General Public License (also called "this License"). Each licensee is addressed as "you". A "library" means a collection of software functions and/or data prepared so as to be conveniently linked with application programs (which use some of those functions and data) to form executables.

The "Library", below, refers to any such software library or work which has been

distributed under these terms. A "work based on the Library" means either the Library or any derivative work under copyright law: that is to say, a work containing the Library or a portion of it, either verbatim or with modifications and/or translated straightforwardly into another language. (Hereinafter, translation is included without limitation in the term "modification".)

"Source code" for a work means the preferred form of the work for making modifications to it. For a library, complete source code means all the source code for all modules it contains, plus any associated interface definition files, plus the scripts used to control compilation and installation of the library.

Activities other than copying, distribution and modification are not covered by this License; they are outside its scope. The act of running a program using the Library is not restricted, and output from such a program is covered only if its contents constitute a work based on the Library (independent of the use of the Library in a tool for writing it). Whether that is true depends on what the Library does and what the program that uses the Library does.

1. You may copy and distribute verbatim copies of the Library's complete source code as you receive it, in any medium, provided that you conspicuously and appropriately publish on each copy an appropriate copyright notice and disclaimer of warranty; keep intact all the notices that refer to this License and to the absence of any warranty; and distribute a copy of this License along with the Library.

You may charge a fee for the physical act of transferring a copy, and you may at your option offer warranty protection in exchange for a fee.

2. You may modify your copy or copies of the Library or any portion of it, thus forming a work based on the Library, and copy and distribute such modifications or work under the terms of Section 1 above, provided that you also meet all of these conditions:

a) The modified work must itself be a software library.

b) You must cause the files modified to carry prominent notices stating that you changed the files and the date of any change.

c) You must cause the whole of the work to be licensed at no charge to all third parties under the terms of this License.

d) If a facility in the modified Library refers to a function or a table of data to be supplied by an application program that uses the facility, other than as an argument passed when the facility is invoked, then you must make a good faith effort to ensure that, in the event an application does not supply such function or table, the facility still operates, and performs whatever part of its purpose remains meaningful.

(For example, a function in a library to compute square roots has a purpose that is entirely well-defined independent of the application. Therefore, Subsection 2d requires that any application-supplied function or table used by this function must be optional: if the application does not supply it, the square root function must still compute square roots.) These requirements apply to the modified work as a whole. If identifiable sections of that work are not derived from the Library, and can be reasonably considered independent and separate works in themselves, then this License, and its terms, do not apply to those sections when you distribute them as separate works. But when you distribute the same sections as part of a whole which is a work based on the Library, the distribution of the whole must be on the terms of this License, whose permissions for other licensees extend to the entire whole, and thus to each and every part regardless of who wrote it. Thus, it is not the intent of this section to claim rights or contest your rights to work written entirely by you; rather, the intent is to exercise the right to control the distribution of derivative or collective works based on the Library. In addition, mere aggregation of another work not based on the Library with the Library (or with a work based on the Library) on a volume of a storage or distribution medium does not bring the other work under the scope of this License.

3. You may opt to apply the terms of the ordinary GNU General Public License instead of this License to a given copy of the Library. To do this, you must alter all the notices that refer to this License, so that they refer to the ordinary GNU General Public License, version 2, instead of to this License. (If a newer version than version 2 of the ordinary GNU General Public License has appeared, then you can specify that version instead if you wish.) Do not make any other change in these notices. Once this change is made in a given

copy, it is irreversible for that copy, so the ordinary GNU General Public License applies to all subsequent copies and derivative works made from that copy. This option is useful when you wish to copy part of the code of the Library into a program that is not a library.

4. You may copy and distribute the Library (or a portion or derivative of it, under Section 2) in object code or executable form under the terms of Sections 1 and 2 above provided that you accompany it with the complete corresponding machine-readable source code, which must be distributed under the terms of Sections 1 and 2 above on a medium customarily used for software interchange.

If distribution of object code is made by offering access to copy from a designated place, then offering equivalent access to copy the source code from the same place satisfies the requirement to distribute the source code, even though third parties are not compelled to copy the source along with the object code.

5. A program that contains no derivative of any portion of the Library, but is designed to work with the Library by being compiled or linked with it, is called a "work that uses the Library". Such a work, in isolation, is not a derivative work of the Library, and therefore falls outside the scope of this License. However, linking a "work that uses the Library" with the Library creates an executable that is a derivative of the Library (because it contains portions of the Library), rather than a "work that uses the library". The executable is therefore covered by this License. Section 6 states terms for distribution of such executables. When a "work that uses the Library" uses material from a header file that is part of the Library, the object code for the work may be a derivative work of the Library even though the source code is not. Whether this is true is especially significant if the work can be linked without the Library, or if the work is itself a library. The threshold for this to be true is not precisely defined by law. If such an object file uses only numerical parameters, data structure layouts and accessors, and small macros and small inline functions (ten lines or less in length), then the use of the object file is unrestricted, regardless of whether it is legally a derivative work. (Executables containing this object code plus portions of the Library will still fall under Section 6.) Otherwise, if the work is

a derivative of the Library, you may distribute the object code for the work under the terms of Section 6. Any executables containing that work also fall under Section 6, whether or not they are linked directly with the Library itself.

6. As an exception to the Sections above, you may also combine or link a "work that uses the Library" with the Library to produce a work containing portions of the Library, and distribute that work under terms of your choice, provided that the terms permit modification of the work for the customer's own use and reverse engineering for debugging such modifications.

You must give prominent notice with each copy of the work that the Library is used in it and that the Library and its use are covered by this License. You must supply a copy of this License. If the work during execution displays copyright notices, you must include the copyright notice for the Library among them, as well as a reference directing the user to the copy of this License. Also, you must do one of these things: a) Accompany the work with the complete corresponding machine-readable source code for the Library including whatever changes were used in the work (which must be distributed under Sections 1 and 2 above); and, if the work is an executable linked with the Library, with the complete machine-readable "work that uses the Library", as object code and/or source code, so that the user can modify the Library and then relink to produce a modified executable containing the modified Library. (It is understood that the user who changes the contents of definitions files in the Library will not necessarily be able to recompile the application to use the modified definitions.) b) Use a suitable shared library mechanism for linking with the Library. A suitable mechanism is one that (1) uses at run time a copy of the library already present on the user's computer system, rather than copying library functions into the executable, and (2) will operate properly with a modified version of the library, if the user installs one, as long as the modified version is interface-compatible with the version that the work was made with. c) Accompany the work with a written offer, valid for at least three years, to give the same user the materials specified in Subsection 6a, above, for a charge no more than the cost of performing this distribution. d) If distribution of the work is made by offering access to copy from a designated place,

offer equivalent access to copy the above specified materials from the same place.

e) Verify that the user has already received a copy of these materials or that you have already sent this user a copy. For an executable, the required form of the "work that uses the Library" must include any data and utility programs needed for reproducing the executable from it. However, as a special exception, the materials to be distributed need not include anything that is normally distributed (in either source or binary form) with the major components (compiler, kernel, and so on) of the operating system on which the executable runs, unless that component itself accompanies the executable.

It may happen that this requirement contradicts the license restrictions of other proprietary libraries that do not normally accompany the operating system. Such a contradiction means you cannot use both them and the Library together in an executable that you distribute.

7. You may place library facilities that are a work based on the Library side-by-side in a single library together with other library facilities not covered by this License, and distribute such a combined library, provided that the separate distribution of the work based on the Library and of the other library facilities is otherwise permitted, and provided that you do these two things:

a) Accompany the combined library with a copy of the same work based on the Library, uncombined with any other library facilities. This must be distributed under the terms of the Sections above.

b) Give prominent notice with the combined library of the fact that part of it is a work based on the Library, and explaining where to find the accompanying uncombined form of the same work.

8. You may not copy, modify, sublicense, link with, or distribute the Library except as expressly provided under this License. Any attempt otherwise to copy, modify, sublicense, link with, or distribute the Library is void, and will automatically terminate your rights under this License. However, parties who have received copies, or rights, from you under this License will not have their licenses terminated so long as such parties remain in full compliance.

9. You are not required to accept this License, since you have not signed it.

However, nothing else grants you permission to modify or distribute the Library or its derivative works. These actions are prohibited by law if you do not accept this License. Therefore, by modifying or distributing the Library (or any work based on the Library), you indicate your acceptance of this License to do so, and all its terms and conditions for copying, distributing or modifying the Library or works based on it.

10. Each time you redistribute the Library (or any work based on the Library), the recipient automatically receives a license from the original licensor to copy, distribute, link with or modify the Library subject to these terms and conditions. You may not impose any further restrictions on the recipients' exercise of the rights granted herein. You are not responsible for enforcing compliance by third parties with this License.

11. If, as a consequence of a court judgment or allegation of patent infringement or for any other reason (not limited to patent issues), conditions are imposed on you (whether by court order, agreement or otherwise) that contradict the conditions of this License, they do not excuse you from the conditions of this License. If you cannot distribute so as to satisfy simultaneously your obligations under this License and any other pertinent obligations, then as a consequence you may not distribute the Library at all. For example, if a patent license would not permit royalty-free redistribution of the Library by all those who receive copies directly or indirectly through you, then the only way you could satisfy both it and this License would be to refrain entirely from distribution of the Library.

If any portion of this section is held invalid or unenforceable under any particular circumstance, the balance of the section is intended to apply, and the section as a whole is intended to apply in other circumstances. It is not the purpose of this section to induce you to infringe any patents or other property right claims or to contest validity of any such claims; this section has the sole purpose of protecting the integrity of the free software distribution system which is implemented by public license practices. Many people have made generous contributions to the wide range of software distributed through that system in reliance on consistent application of that system; it is up to the author/donor to decide if he or she

is willing to distribute software through any other system and a licensee cannot impose that choice. This section is intended to make thoroughly clear what is believed to be a consequence of the rest of this License.

12. If the distribution and/or use of the Library is restricted in certain countries either by patents or by copyrighted interfaces, the original copyright holder who places the Library under this License may add an explicit geographical distribution limitation excluding those countries, so that distribution is permitted only in or among countries not thus excluded. In such case, this License incorporates the limitation as if written in the body of this License.

13. The Free Software Foundation may publish revised and/or new versions of the Lesser General Public License from time to time. Such new versions will be similar in spirit to the present version, but may differ in detail to address new problems or concerns. Each version is given a distinguishing version number. If the Library specifies a version number of this License which applies to it and "any later version", you have the option of following the terms and conditions either of that version or of any later version published by the Free Software Foundation. If the Library does not specify a license version number, you may choose any version ever published by the Free Software Foundation.

14. If you wish to incorporate parts of the Library into other free programs whose distribution conditions are incompatible with these, write to the author to ask for permission. For software which is copyrighted by the Free Software Foundation, write to the Free Software Foundation; we sometimes make exceptions for this. Our decision will be guided by the two goals of preserving the free status of all derivatives of our free software and of promoting the sharing and reuse of software generally.

NO WARRANTY

15. BECAUSE THE LIBRARY IS LICENSED FREE OF CHARGE, THERE IS NO WARRANTY FOR THE LIBRARY, TO THE EXTENT PERMITTED BY APPLICABLE LAW. EXCEPT WHEN OTHERWISE STATED IN WRITING THE COPYRIGHT HOLDERS AND/OR OTHER PARTIES PROVIDE THE LIBRARY "AS IS" WITHOUT WARRANTY OF ANY KIND, EITHER EXPRESSED OR IMPLIED, INCLUDING, BUT NOT LIMITED TO, THE IM-

PLIED WARRANTIES OF MERCHANTABILITY AND FITNESS FOR A PARTICULAR PURPOSE. THE ENTIRE RISK AS TO THE QUALITY AND PERFORMANCE OF THE LIBRARY IS WITH YOU. SHOULD THE LIBRARY PROVE DEFECTIVE, YOU ASSUME THE COST OF ALL NECESSARY SERVICING, REPAIR OR CORRECTION.

16. IN NO EVENT UNLESS REQUIRED BY APPLICABLE LAW OR AGREED TO IN WRITING WILL ANY COPYRIGHT HOLDER, OR ANY OTHER PARTY WHO MAY MODIFY AND/OR REDISTRIBUTE THE LIBRARY AS PERMITTED ABOVE, BE LIABLE TO YOU FOR DAMAGES, INCLUDING ANY GENERAL, SPECIAL, INCIDENTAL OR CONSEQUENTIAL DAMAGES ARISING OUT OF THE USE OR INABILITY TO USE THE LIBRARY (INCLUDING BUT NOT LIMITED TO LOSS OF DATA OR DATA BEING RENDERED INACCURATE OR LOSSES SUSTAINED BY YOU OR THIRD PARTIES OR A FAILURE OF THE LIBRARY TO OPERATE WITH ANY OTHER SOFTWARE), EVEN IF SUCH HOLDER OR OTHER PARTY HAS BEEN ADVISED OF THE POSSIBILITY OF SUCH DAMAGES.

END OF TERMS AND CONDITIONS

How to Apply These Terms to Your New Libraries

If you develop a new library, and you want it to be of the greatest possible use to the public, we recommend making it free software that everyone can redistribute and change. You can do so by permitting redistribution under these terms (or, alternatively, under the terms of the ordinary General Public License). To apply these terms, attach the following notices to the library. It is safest to attach them to the start of each source file to most effectively convey the exclusion of warranty; and each file should have at least the "copyright" line and a pointer to where the full notice is found.

<one line to give the library's name and a brief idea of what it does.>

Copyright (C) <year> <name of author>

This library is free software; you can redistribute it and/or modify it under the terms of the GNU Lesser General Public License as published by the Free Software Foundation; either version 2.1 of the License, or (at your option) any later version.

This library is distributed in the hope that it will be useful, but WITHOUT ANY WARRANTY; without even the implied warranty of MER-

CHANTABILITY or FITNESS FOR A PARTICULAR PURPOSE. See the GNU Lesser General Public License for more details. You should have received a copy of the GNU Lesser General Public License along with this library; if not, write to the Free Software Foundation, Inc., 51 Franklin Street, Fifth Floor, Boston, MA 02110-1301 USA Also add information on how to contact you by electronic and paper mail. You should also get your employer (if you work as a programmer) or your school, if any, to sign a "copyright disclaimer" for the library, if necessary. Here is a sample; alter the names: Yoyodyne, Inc., hereby disclaims all copyright interest in the library `Frob' (a library for tweaking knobs) written by James Random Hacker.

<signature of Ty Coon>, 1 April 1990
Ty Coon, President of Vice
That's all there is to it!

ICU License - ICU 1.8.1 and later

COPYRIGHT AND PERMISSION NOTICE

Copyright (c) 1995-2009 International Business Machines Corporation and others

All rights reserved.

Permission is hereby granted, free of charge, to any person obtaining a copy of this software and associated documentation files (the "Software"), to deal in the Software without restriction, including without limitation the rights to use, copy, modify, merge, publish, distribute, and/or sell copies of the Software, and to permit persons to whom the Software is furnished to do so, provided that the above copyright notice(s) and this permission notice appear in all copies of the Software and that both the above copyright notice(s) and this permission notice appear in supporting documentation.

THE SOFTWARE IS PROVIDED "AS IS", WITHOUT WARRANTY OF ANY KIND, EXPRESS OR IMPLIED, INCLUDING BUT NOT LIMITED TO THE WARRANTIES OF MERCHANTABILITY, FITNESS FOR A PARTICULAR PURPOSE AND NONINFRINGEMENT OF THIRD PARTY RIGHTS. IN NO EVENT SHALL THE COPYRIGHT HOLDER OR HOLDERS INCLUDED IN THIS NOTICE BE LIABLE FOR ANY CLAIM, OR ANY SPECIAL INDIRECT OR CONSEQUENTIAL DAMAGES, OR ANY DAMAGES WHATSOEVER RESULTING FROM

LOSS OF USE, DATA OR PROFITS, WHETHER IN AN ACTION OF CONTRACT, NEGLIGENCE OR OTHER TORTIOUS ACTION, ARISING OUT OF OR IN CONNECTION WITH THE USE OR PERFORMANCE OF THIS SOFTWARE.

Except as contained in this notice, the name of a copyright holder shall not be used in advertising or otherwise to promote the sale, use or other dealings in this Software without prior written authorization of the copyright holder.

All trademarks and registered trademarks mentioned herein are the property of their respective owners.

LICENSE ISSUES

LICENSE ISSUES

=====

The OpenSSL toolkit stays under a dual license, i.e. both the conditions of the OpenSSL License and the original SSLeay license apply to the toolkit.

See below for the actual license texts. Actually both licenses are BSD-style

Open Source licenses. In case of any license issues related to OpenSSL please contact openssl-core@openssl.org.

OpenSSL License

/* =====
=====

* Copyright (c) 1998-2008 The OpenSSL Project. All rights reserved.

*

* Redistribution and use in source and binary forms, with or without

* modification, are permitted provided that the following conditions

* are met:

*

* 1. Redistributions of source code must retain the above copyright

* notice, this list of conditions and the following disclaimer.

*

* 2. Redistributions in binary form must reproduce the above copyright

* notice, this list of conditions and the follow-

ing disclaimer in

- * the documentation and/or other materials provided with the
- * distribution.

- * 3. All advertising materials mentioning features or use of this

- * software must display the following acknowledgment:

- * "This product includes software developed by the OpenSSL Project

- * for use in the OpenSSL Toolkit. (<http://www.openssl.org/>)"

- * 4. The names "OpenSSL Toolkit" and "OpenSSL Project" must not be used to

- * endorse or promote products derived from this software without

- * prior written permission. For written permission, please contact

- * openssl-core@openssl.org.

- * 5. Products derived from this software may not be called "OpenSSL"

- * nor may "OpenSSL" appear in their names without prior written

- * permission of the OpenSSL Project.

- * 6. Redistributions of any form whatsoever must retain the following

- * acknowledgment:

- * "This product includes software developed by the OpenSSL Project

- * for use in the OpenSSL Toolkit (<http://www.openssl.org/>)"

- * THIS SOFTWARE IS PROVIDED BY THE OpenSSL PROJECT ``AS IS'' AND ANY

- * EXPRESSED OR IMPLIED WARRANTIES, INCLUDING, BUT NOT LIMITED TO, THE

- * IMPLIED WARRANTIES OF MERCHANTABILITY AND FITNESS FOR A PARTICULAR

- * PURPOSE ARE DISCLAIMED. IN NO EVENT SHALL THE OpenSSL PROJECT OR

- * ITS CONTRIBUTORS BE LIABLE FOR ANY DIRECT, INDIRECT, INCIDENTAL,

- * SPECIAL, EXEMPLARY, OR CONSEQUENTIAL DAMAGES (INCLUDING, BUT

- * NOT LIMITED TO, PROCUREMENT OF SUBSTITUTE GOODS OR SERVICES;

- * LOSS OF USE, DATA, OR PROFITS; OR BUSINESS INTERRUPTION)

- * HOWEVER CAUSED AND ON ANY THEORY OF LIABILITY, WHETHER IN CONTRACT,

- * STRICT LIABILITY, OR TORT (INCLUDING NEGLIGENCE OR OTHERWISE)

- * ARISING IN ANY WAY OUT OF THE USE OF THIS SOFTWARE, EVEN IF ADVISED

- * OF THE POSSIBILITY OF SUCH DAMAGE.

- * =====
- * =====
- * =====

- * This product includes cryptographic software written by Eric Young

- * (ey@cryptsoft.com). This product includes software written by Tim

- * Hudson (tjh@cryptsoft.com).

- *

- */

Original SSLeay License

```
/* Copyright (C) 1995-1998 Eric Young (ey@cryptsoft.com)
```

```
* All rights reserved.
```

```
*
```

```
* This package is an SSL implementation written
```

```
* by Eric Young (ey@cryptsoft.com).
```

```
* The implementation was written so as to conform with Netscapes SSL.
```

```
*
```

```
* This library is free for commercial and non-commercial use as long as
```

```
* the following conditions are aheared to. The following conditions
```

```
* apply to all code found in this distribution, be it the RC4, RSA,
```

```
* lhash, DES, etc., code; not just the SSL code. The SSL documentation
```

```
* included with this distribution is covered by the same copyright terms
```

```
* except that the holder is Tim Hudson (tjh@cryptsoft.com).
```

```
*
```

```
* Copyright remains Eric Young's, and as such any Copyright notices in
```

```
* the code are not to be removed.
```

```
* If this package is used in a product, Eric Young should be given attribution
```

```
* as the author of the parts of the library used.
```

```
* This can be in the form of a textual message at program startup or
```

```
* in documentation (online or textual) provided with the package.
```

```
*
```

- * Redistribution and use in source and binary forms, with or without
- * modification, are permitted provided that the following conditions
- * are met:
- * 1. Redistributions of source code must retain the copyright
- * notice, this list of conditions and the following disclaimer.
- * 2. Redistributions in binary form must reproduce the above copyright
- * notice, this list of conditions and the following disclaimer in the
- * documentation and/or other materials provided with the distribution.
- * 3. All advertising materials mentioning features or use of this software
- * must display the following acknowledgement:
- * "This product includes cryptographic software written by
- * Eric Young (eay@cryptsoft.com)"
- * The word 'cryptographic' can be left out if the routines from the library
- * being used are not cryptographic related :-).
- * 4. If you include any Windows specific code (or a derivative thereof) from
- * the apps directory (application code) you must include an acknowledgement:
- * "This product includes software written by Tim Hudson (tjh@cryptsoft.com)"
- *
- * THIS SOFTWARE IS PROVIDED BY ERIC YOUNG ``AS IS'' AND
- * ANY EXPRESS OR IMPLIED WARRANTIES, INCLUDING, BUT NOT LIMITED TO, THE
- * IMPLIED WARRANTIES OF MERCHANTABILITY AND FITNESS FOR A PARTICULAR PURPOSE
- * ARE DISCLAIMED. IN NO EVENT SHALL THE AUTHOR OR CONTRIBUTORS BE LIABLE
- * FOR ANY DIRECT, INDIRECT, INCIDENTAL, SPECIAL, EXEMPLARY, OR CONSEQUENTIAL
- * DAMAGES (INCLUDING, BUT NOT LIMITED TO, PROCUREMENT OF SUBSTITUTE GOODS
- * OR SERVICES; LOSS OF USE, DATA, OR PROFITS; OR BUSINESS INTERRUPTION)
- * HOWEVER CAUSED AND ON ANY THEORY OF LIABILITY, WHETHER IN CONTRACT, STRICT
- * LIABILITY, OR TORT (INCLUDING NEGLIGENCE OR OTHERWISE) ARISING IN ANY WAY
- * OUT OF THE USE OF THIS SOFTWARE, EVEN

IF ADVISED OF THE POSSIBILITY OF
* SUCH DAMAGE.

- *
- * The licence and distribution terms for any publically available version or
- * derivative of this code cannot be changed. i.e. this code cannot simply be
- * copied and put under another distribution licence
- * [including the GNU Public Licence.]
- */

zlib

/* zlib.h -- interface of the 'zlib' general purpose compression library
version 1.2.3, July 18th, 2005

Copyright (C) 1995-2005 Jean-loup Gailly and Mark Adler

This software is provided 'as-is', without any express or implied warranty. In no event will the authors be held liable for any damages arising from the use of this software.

Permission is granted to anyone to use this software for any purpose, including commercial applications, and to alter it and redistribute it freely, subject to the following restrictions:

1. The origin of this software must not be misrepresented; you must not claim that you wrote the original software. If you use this software in a product, an acknowledgment in the product documentation would be appreciated but is not required.
2. Altered source versions must be plainly marked as such, and must not be misrepresented as being the original software.
3. This notice may not be removed or altered from any source distribution.

Jean-loup Gailly jloup@gzip.org
Mark Adler madler@alumni.caltech.edu
*/

The FreeType Project LICENSE
2006-Jan-27

Copyright 1996-2002, 2006 by David Turner,

Robert Wilhelm, and Werner Lemberg

Introduction

=====

The FreeType Project is distributed in several archive packages;

some of them may contain, in addition to the FreeType font engine, various tools and contributions which rely on, or relate to, the FreeType Project.

This license applies to all files found in such packages, and which do not fall under their own explicit license. The license affects thus the FreeType font engine, the test programs, documentation and makefiles, at the very least.

This license was inspired by the BSD, Artistic, and IJG (Independent JPEG Group) licenses, which all encourage inclusion and use of free software in commercial and freeware products alike. As a consequence, its main points are that:

We don't promise that this software works. However, we will be interested in any kind of bug reports. (`as is' distribution)

You can use this software for whatever you want, in parts or full form, without having to pay us. (`royalty-free' usage)

You may not pretend that you wrote this software. If you use it, or only parts of it, in a program, you must acknowledge somewhere in your documentation that you have used the FreeType code. (`credits')

We specifically permit and encourage the inclusion of this software, with or without modifications, in commercial products. We disclaim all warranties covering The FreeType Project and assume no liability related to The FreeType Project.

Finally, many people asked us for a preferred form for a credit/disclaimer to use in compliance with this license. We thus encourage you to use the following text:

""""

Portions of this software are copyright © <year> The FreeType Project (www.freetype.org). All rights reserved.

""""

Please replace <year> with the value from the FreeType version you actually use.

Legal Terms

=====

0. Definitions

Throughout this license, the terms `package', `FreeType Project', and `FreeType archive' refer to the set of files originally distributed by the authors (David Turner, Robert Wilhelm, and Werner Lemberg) as the `FreeType Project', be they named as alpha, beta or final release.

`You' refers to the licensee, or person using the project, where `using' is a generic term including compiling the project's source code as well as linking it to form a `program' or `executable'.

This program is referred to as `a program using the FreeType engine'.

This license applies to all files distributed in the original FreeType Project, including all source code, binaries and documentation, unless otherwise stated in the file in its original, unmodified form as distributed in the original archive.

If you are unsure whether or not a particular file is covered by this license, you must contact us to verify this.

The FreeType Project is copyright (C) 1996-2000 by David Turner,

Robert Wilhelm, and Werner Lemberg. All rights reserved except as specified below.

1. No Warranty

THE FREETYPE PROJECT IS PROVIDED `AS IS' WITHOUT WARRANTY OF ANY KIND, EITHER EXPRESS OR IMPLIED, INCLUDING, BUT NOT LIMITED TO, WARRANTIES OF MERCHANTABILITY AND

FITNESS FOR A PARTICULAR PURPOSE. IN NO EVENT WILL ANY OF THE AUTHORS OR COPYRIGHT HOLDERS BE LIABLE FOR ANY DAMAGES CAUSED BY THE USE OR THE INABILITY TO USE, OF THE FREETYPE PROJECT.

2. Redistribution

This license grants a worldwide, royalty-free, perpetual and irrevocable right and license to use, execute, perform, compile, display, copy, create derivative works of, distribute and sublicense the FreeType Project (in both source and object code forms) and derivative works thereof for any purpose; and to authorize others to exercise some or all of the rights granted herein, subject to the following conditions:

Redistribution of source code must retain this license file ('FTL.TXT') unaltered; any additions, deletions or changes to the original files must be clearly indicated in accompanying documentation. The copyright notices of the unaltered, original files must be preserved in all copies of source files.

Redistribution in binary form must provide a disclaimer that states that the software is based in part of the work of the FreeType Team, in the distribution documentation. We also encourage you to put an URL to the FreeType web page in your documentation, though this isn't mandatory.

These conditions apply to any software derived from or based on the FreeType Project, not just the unmodified files. If you use our work, you must acknowledge us. However, no fee need be paid to us.

3. Advertising

Neither the FreeType authors and contributors nor you shall use the name of the other for commercial, advertising, or promotional purposes without specific prior written permission.

We suggest, but do not require, that you use one or more of the following phrases to refer to this software in your documentation or advertising materials: 'FreeType Project', 'FreeType Engine', 'FreeType library', or 'FreeType Distribution'.

As you have not signed this license, you are not required to accept it. However, as the FreeType Project is copyrighted material, only this license, or another one contracted with the authors, grants you the right to use, distribute, and modify it.

Therefore, by using, distributing, or modifying the FreeType Project, you indicate that you understand and accept all the terms of this license.

4. Contacts

There are two mailing lists related to FreeType:

freetype@nongnu.org

Discusses general use and applications of FreeType, as well as future and wanted additions to the library and distribution.

If you are looking for support, start in this list if you

haven't found anything to help you in the documentation.

freetype-devel@nongnu.org

Discusses bugs, as well as engine internals, design issues, specific licenses, porting, etc.

Our home page can be found at

<http://www.freetype.org>

Expat

Copyright (c) 1998, 1999, 2000 Thai Open Source Software Center Ltd and Clark Cooper
Copyright (c) 2001, 2002, 2003, 2004, 2005, 2006 Expat maintainers.

Permission is hereby granted, free of charge, to any person obtaining a copy of this software and associated documentation files (the Software), to deal in the Software without restriction, including without limitation the rights to use, copy, modify, merge, publish, distribute, sublicense, and/or sell copies of the Software, and to permit persons to whom the Software is furnished to do so, subject to the following conditions:

The above copyright notice and this permission notice shall be included in all copies or substantial portions of the Software.

THE SOFTWARE IS PROVIDED "AS IS", WITHOUT WARRANTY OF ANY KIND, EXPRESS OR IMPLIED, INCLUDING BUT NOT LIMITED TO THE WARRANTIES OF MERCHANTABILITY, FITNESS FOR A PARTICULAR PURPOSE AND NONINFRINGEMENT. IN NO EVENT SHALL THE AUTHORS OR COPYRIGHT HOLDERS BE LIABLE FOR ANY CLAIM, DAMAGES OR OTHER LIABILITY, WHETHER IN AN ACTION OF CONTRACT, TORT OR OTHERWISE, ARISING FROM, OUT OF OR IN CONNECTION WITH THE SOFTWARE OR THE USE OR OTHER DEALINGS IN THE SOFTWARE.

Curl

COPYRIGHT AND PERMISSION NOTICE

Copyright (c) 1996 - 2008, Daniel Stenberg, <daniel@haxx.se>.

All rights reserved.

Permission to use, copy, modify, and distribute this software for any purpose with or without fee is hereby granted, provided that the above copyright notice and this permission notice appear in all copies.

THE SOFTWARE IS PROVIDED "AS IS", WITHOUT WARRANTY OF ANY KIND, EXPRESS OR IMPLIED, INCLUDING BUT NOT LIMITED TO THE WARRANTIES OF MERCHANTABILITY, FITNESS FOR A PARTICULAR PURPOSE AND NONINFRINGEMENT OF THIRD PARTY RIGHTS. IN NO EVENT SHALL THE AUTHORS OR COPYRIGHT HOLDERS BE LIABLE FOR ANY CLAIM, DAMAGES OR OTHER LIABILITY, WHETHER IN AN ACTION OF CONTRACT, TORT OR OTHERWISE, ARISING FROM, OUT OF OR IN CONNECTION WITH THE SOFTWARE OR THE USE OR OTHER DEALINGS IN THE SOFTWARE. Except as contained in this notice, the name of a copyright holder shall not be used in advertising or otherwise to promote the sale, use or other dealings in this Software without prior written authorization of the copyright holder.

IJG

1. We don't promise that this software works. (But if you find any bugs, please let us know!)
2. You can use this software for whatever you want. You don't have to pay us.
3. You may not pretend that you wrote this software. If you use it in a program, you must acknowledge somewhere in your documentation that you've used the IJG code.

In legalese:

The authors make NO WARRANTY or representation, either express or implied, with respect to this software, its quality, accuracy, merchantability, or fitness for a particular purpose. This software is provided "AS IS", and you, its user, assume the entire risk as to its quality and accuracy.

This software is copyright (C) 1991-1998, Thomas G. Lane.

All Rights Reserved except as specified below.

Permission is hereby granted to use, copy, modify, and distribute this software (or portions thereof) for any purpose, without fee, subject to these conditions:

- (1) If any part of the source code for this software is distributed, then this README file must be included, with this copyright and no-warranty notice unaltered; and any additions, deletions, or changes to the original files must be clearly indicated in accompanying documentation.
- (2) If only executable code is distributed, then the accompanying documentation must state that "this software is based in part on the work of the Independent JPEG Group".
- (3) Permission for use of this software is granted only if the user accepts full responsibility for any undesirable consequences; the authors accept NO LIABILITY for damages of any kind.

These conditions apply to any software derived from or based on the IJG code, not just to the unmodified library. If you use our work, you ought to acknowledge us.

Permission is NOT granted for the use of any IJG author's name or company name in advertising or publicity relating to this software or products derived from it. This software may be referred to only as "the Independent JPEG Group's software".

We specifically permit and encourage the use of this software as the basis of commercial products, provided that all warranty or liability claims are assumed by the product vendor.

ansi2knr.c is included in this distribution by permission of L. Peter Deutsch, sole proprietor of its copyright holder, Aladdin Enterprises of Menlo Park, CA. ansi2knr.c is NOT covered by the above copyright and conditions, but instead by the usual distribution terms of the Free Software Foundation; principally, that you must include source code if you redistribute it. (See the file ansi2knr.c for full details.) However, since ansi2knr.c is not needed as part of any program generated from the IJG code, this does not limit you more than the foregoing paragraphs do.

The Unix configuration script "configure" was produced with GNU Autoconf.

It is copyright by the Free Software Foundation but is freely distributable.

The same holds for its supporting scripts (config.guess, config.sub, ltconfig, ltmain.sh). Another support script, install-sh, is copyright by M.I.T. but is also freely distributable.

It appears that the arithmetic coding option of the JPEG spec is covered by patents owned by IBM, AT&T, and Mitsubishi. Hence arithmetic coding cannot legally be used without obtaining one or more licenses. For this reason, support for arithmetic coding has been removed from the free JPEG software.

(Since arithmetic coding provides only a marginal gain over the unpatented Huffman mode, it is unlikely that very many implementations will support it.)

So far as we are aware, there are no patent restrictions on the remaining code.

The IJG distribution formerly included code to read and write GIF files.

To avoid entanglement with the Unisys LZW patent, GIF reading support has been removed altogether, and the GIF writer has been simplified to produce uncompressed GIFs. This technique does not use the LZW algorithm; the resulting GIF files are larger than usual, but are readable by all standard GIF decoders.

We are required to state that "The Graphics Interchange Format(c) is the Copyright property of CompuServe Incorporated. GIF(sm) is a Service Mark property of CompuServe Incorporated."

CharisSIL OFL

SIL OPEN FONT LICENSE Version 1.1 - 26 February 2007

PREAMBLE

The goals of the Open Font License (OFL) are to stimulate worldwide development of collaborative font projects, to support the font creation efforts of academic and linguistic communities, and to provide a free and open framework in which fonts may be shared and improved in partnership with others.

The OFL allows the licensed fonts to be used, studied, modified and redistributed freely as long as they are not sold by themselves. The fonts, including any derivative works, can be bundled, embedded, redistributed and/or sold with any software provided that any reserved names are not used by derivative works. The fonts and derivatives, however, cannot be released under any other type of license. The requirement for fonts to remain under this license does not apply to any document created using the fonts or their derivatives.

DEFINITIONS

Font Software refers to the set of files released by the Copyright Holder(s) under this license and clearly marked as such. This may include source files, build scripts and documentation.

Reserved Font Name refers to any names specified as such after the copyright statement(s).

Original Version refers to the collection of Font Software components as distributed by the Copyright Holder(s).

Modified Version refers to any derivative made by adding to, deleting, or substituting -- in part or in whole -- any of the components of the Original Version, by changing formats or by porting the Font Software to a new environment.

Author refers to any designer, engineer, programmer, technical writer or other person who contributed to the Font Software.

PERMISSION & CONDITIONS

Permission is hereby granted, free of charge, to any person obtaining a copy of the Font Software, to use, study, copy, merge, embed, modify, redistribute, and sell modified and unmodified copies of the Font Software, subject to the following conditions:

- 1) Neither the Font Software nor any of its individual components, in Original or Modified Versions, may be sold by itself.
- 2) Original or Modified Versions of the Font Software may be bundled, redistributed and/or sold with any software, provided that each copy contains the above copyright notice and this license. These can be included either as stand-alone text files, human-readable headers or in the appropriate machine-readable metadata fields within text or binary files as long as those fields can be easily viewed by the user.
- 3) No Modified Version of the Font Software may use the Reserved Font Name(s) unless explicit written permission is granted by the corresponding Copyright Holder. This restriction only applies to the primary font name as presented to the users.
- 4) The name(s) of the Copyright Holder(s) or the Author(s) of the Font Software shall not be used to promote, endorse or advertise any Modified Version, except to acknowledge the contribution(s) of the Copyright Holder(s) and the Author(s) or with their explicit written permission.
- 5) The Font Software, modified or unmodified, in part or in whole, must be distributed entirely under this license, and must not be distributed under any other license. The requirement for fonts to remain under this license does not apply to any document created using the Font Software.

TERMINATION

This license becomes null and void if any of the above conditions are not met.

DISCLAIMER

THE FONT SOFTWARE IS PROVIDED "AS IS", WITHOUT WARRANTY OF ANY KIND, EXPRESS OR IMPLIED, INCLUDING BUT NOT LIMITED TO ANY WARRANTIES OF MERCHANTABILITY, FITNESS FOR A PARTICULAR PURPOSE AND NONINFRINGEMENT OF COPYRIGHT, PATENT, TRADEMARK, OR OTHER RIGHT. IN NO EVENT SHALL THE COPYRIGHT HOLDER BE LIABLE FOR ANY CLAIM, DAMAGES OR OTHER LIABILITY, INCLUDING ANY GENERAL, SPECIAL, INDIRECT, INCIDENTAL, OR CONSEQUENTIAL DAMAGES, WHETHER IN AN ACTION OF CONTRACT, TORT OR OTHERWISE, ARISING FROM, OUT OF THE USE OR INABILITY TO USE THE FONT SOFTWARE OR FROM OTHER DEALINGS IN THE FONT SOFTWARE.